



Cabinet Locks

In or Out... we make it Easy!

Instructions For Lock Mode Change

1. Remove the 4 Screws on the bottom.
2. Remove base plate and solenoid.
3. Turn assembly 180° and re-route wires to cut out.
4. Install into housing and insert the 4 Screws.

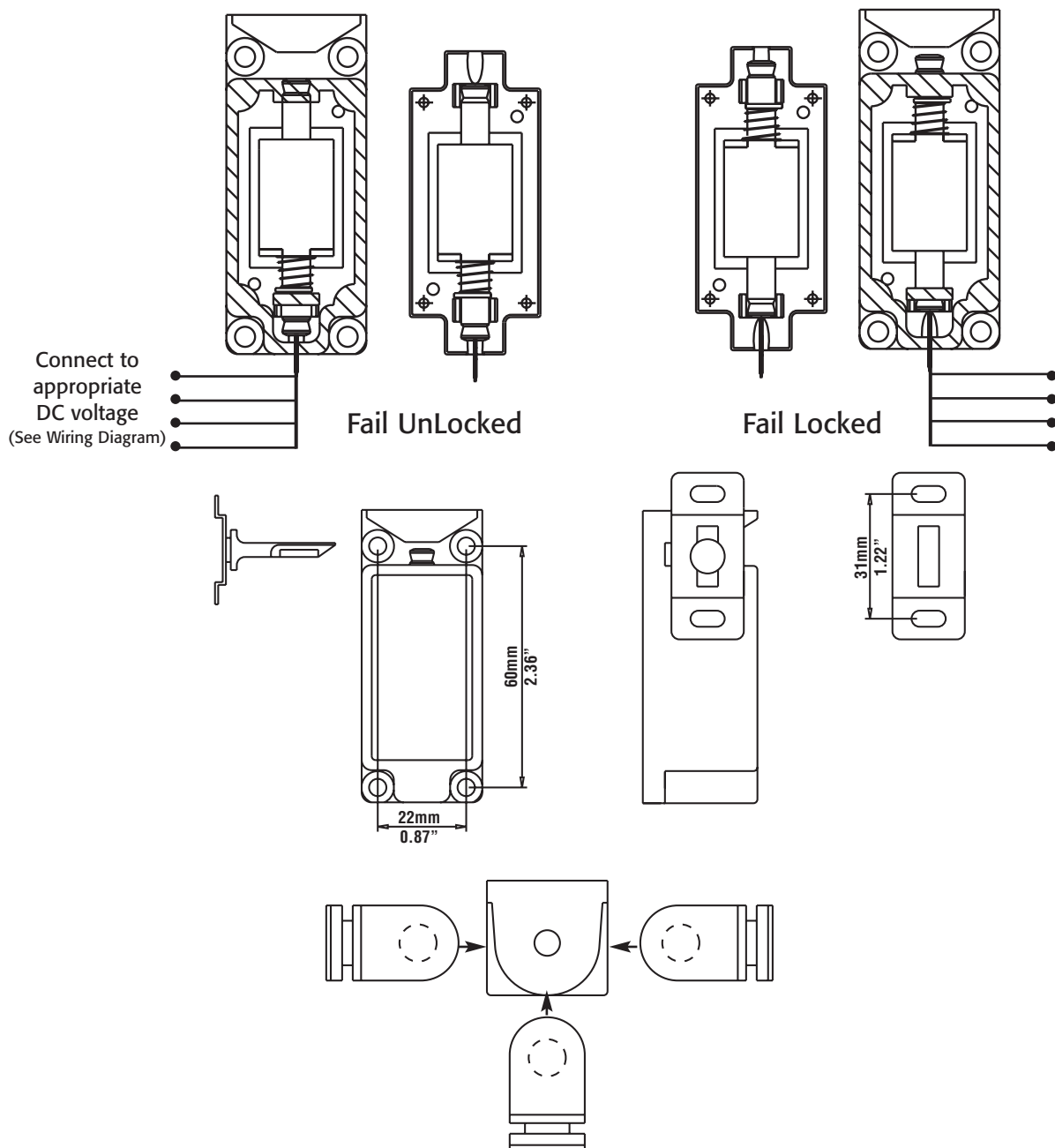

3513 Installation Instructions (Continued)

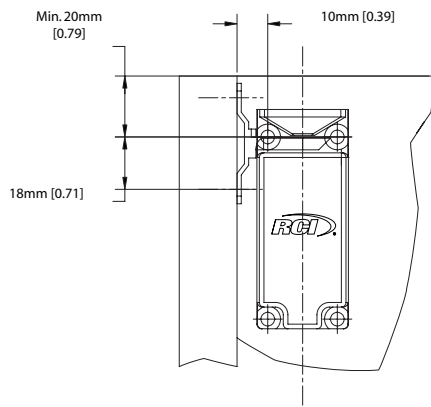
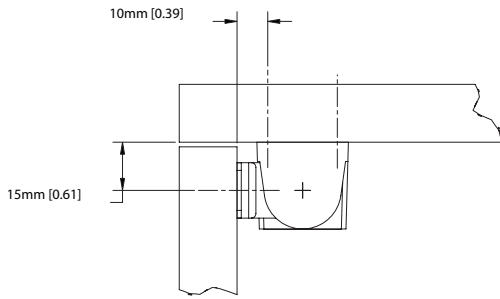

Installation Dimensions

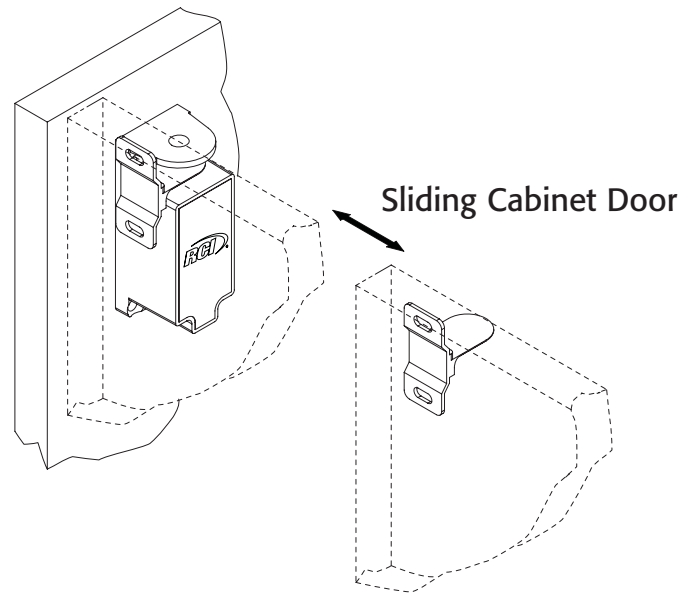
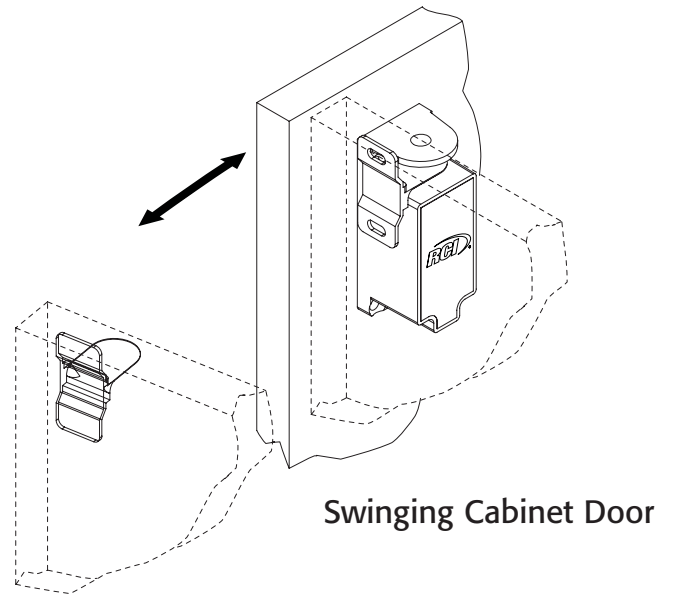

Parts Checklist

QTY	Description
4	Flat Head Wood Screws
2	Pan Head Wood Screws

Cabinet Lock Dual Voltage Wiring Diagram

