

Fixed Housings

		SHB-4300H	SHB-4300H1	SHB-4300H2	SHB-4300HP	SHB-4200	SHB-4200H	STH-200
Open Type		Side open	Side open	Side open	Side open	Side open	Side open	Side open
Cable Entry		Nylon gland	Nylon gland	Nylon gland	Nylon gland	Nylon gland	Nylon gland	Nylon gland
Operating Temperature	Set	-35°C ~ +50°C (-31°F ~ +122°F)	-50°C ~ +50°C (-58°F ~ +122°F)	-50°C ~ +50°C (-58°F ~ +122°F)	-35°C ~ +50°C (-31°F ~ +122°F)	-15°C ~ +45°C (+5°F ~ +113°F)	-35°C ~ +50°C (-31°F ~ +122°F)	-15°C ~ +50°C (+5°F ~ +122°F)
	Heater	5°C ± 5°C on (1 x heater : 20W)	5°C ± 5°C on (2 x heater : 20W)	5°C ± 5°C on (2 x heater : 20W)	5°C ± 5°C on (1 x heater : 9W)	N/A	4°C ± 3°C on (1 x heater : 20W)	N/A
	Blower	+45°C ± 5°C on (1 x blower : 2W)	+45°C ± 5°C on (1 x blower : 2W)	+45°C ± 5°C on (1 x blower : 5W)	+35°C ± 2°C (1 x blower : 2W)	N/A	+45°C ~ +5°C on (1 x blower : 1.6W)	N/A
Defroster	N/A	Always on (8W)	Always on (10W)	Always on (5W)	N/A	N/A	N/A	
Operating Humidity		0 ~ 90% RH	0 ~ 90% RH	0 ~ 90% RH	0 ~ 90% RH	0 ~ 90% RH	0 ~ 90% RH	0 ~ 90% RH
Materials		Aluminum	Aluminum	Aluminum	Aluminum	Aluminum	Aluminum	Aluminum
Ingress Protection		IP66	IP66	IP66	IP66	IP3	IP3	N/A
Dimensions (WxHxD)	External	184.0 x 127.0 x 460.0mm (7.24" x 5" x 18.11")	184.0 x 127.0 x 460.0mm (7.24" x 5" x 18.11")	184.0 x 127.0 x 460.0mm (7.24" x 5" x 18.11")	184.0 x 127.0 x 460.0mm (7.24" x 5" x 18.11")	148.0 x 107.0 x 421.0mm (5.83" x 4.21" x 16.57")	148.0 x 107.0 x 421.0mm (5.83" x 4.21" x 16.57")	118.0 x 92.0 x 405.0mm (4.65" x 3.62" x 15.94")
	Internal	100.0 x 80.0 x 383.0mm (3.94" x 3.15" x 15.08")	100.0 x 80.0 x 383.0mm (3.94" x 3.15" x 15.08")	100.0 x 80.0 x 383.0mm (3.94" x 3.15" x 15.08")	91.0 x 78.0 x 250.0mm (3.58" x 3.10" x 9.84")	84.0 x 69.0 x 319.0mm (3.31" x 2.72" x 12.56")	84.0 x 69.0 x 319.0mm (3.31" x 2.72" x 12.56")	70.0 x 56.0 x 360.0mm (2.76" x 2.2" x 14.17")
Weight		3.5Kg (7.72 lb)	3.7Kg (8.16 lb)	3.7Kg (8.16 lb)	3.5Kg (7.72 lb)	1Kg (2.2 lb)	1.1Kg (2.3 lb)	1Kg (2.2 lb)
Input Voltage		24V AC	24V AC	230V AC	PoE(IEEE802.3at)&12V DC	N/A	24V AC	N/A
Power Consumption		25W	55W	55W	16W	N/A	21.6W	N/A
Color		Ivory	Ivory	Ivory	Ivory	Ivory	Ivory	Ivory
Applicable Model		Box cameras (Network / Analog)	Box cameras (Network / Analog)	Box cameras (Network / Analog)	Box cameras (Network)	Box cameras (Network / Analog)	Box cameras (Network / Analog)	Box cameras (Network / Analog)
Certification		CE (Class A)	CE (Class A)	CE (Class A)	CE (Class A)	N/A	N/A	N/A

* The latest product information / specification can be found at hanwha-security.com
 * Design and specifications are subject to change without notice.

Dimensions

Unit : mm (inch)

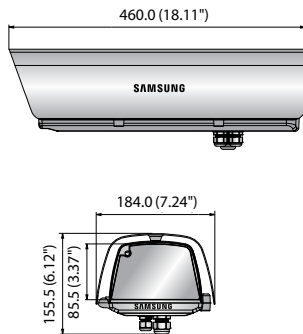

SHB-4300H/4300H1/4300H2/4300HP

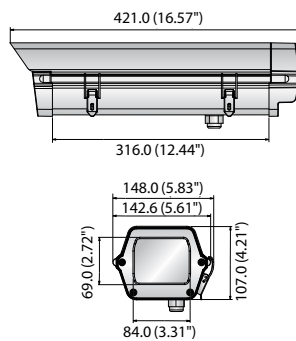

SHB-4200/4200H

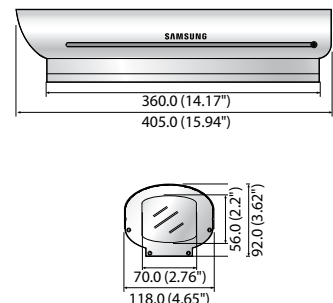

STH-200