

MEM2400LED Mechanical Electro Magnetic Lock for Inward Opening Doors

Introduction

The patented MEM2400LED Mechanical Electro Magnet locking device is designed for securing all types of **inward opening** side hung hinged doors. The MEM Lock has a holding force of more than 680Kg and is equipped with a LED light feature for Secure (green) / Insecure (red) local monitoring indication on the device. The MEM2400LED has been Fire Tested for up to 4 hours to both AS & BS Standards. The MEM2400LED locking device is capable of releasing under door back pressure (pre-load) of up to 70KG.

Monitoring

The MEM2400LED lock is provided with a number of unique monitoring features for either local or remote indication:

- i. Door Status Signal (DSS) 1 set of normally open contacts (N/O -- blue).
- ii. Lock Status Signal (LSS) 1 set of normally open contacts (N/O -- yellow).
- iii. Early Warning (EW) x 2. 2 sets of single throw double pole switches.
EW1: (N/O -- purple); (COM -- orange); (N/C -- pink).
EW2: (N/O -- gray); (COM -- brown); (N/C -- white).

Functions

The MEM2400LED Mechanical Electro Magnetic Lock operates on either 12 or 24 VDC. It is set ex-factory on 24VDC and can be changed over to 12V DC by voltage jumper selection. When power is applied to the lock and the door is in the closed position the Armature Plate is magnetically attracted to the MEM device and both the DSS & LSS switches change status to NC.

When pressure is applied to the door in an attempt to open it unauthorised, the MEM Lock provides the patented local or remote "Early Warning" (EW) security alarm indication.

Power Supply

The operating switch or controlling contacts must be installed directly from the power source across the MEM Lock. The DC output of the power supply must NOT be connected to earth but floating to prevent shock and possible damage to the unit.

Wiring and Power Input

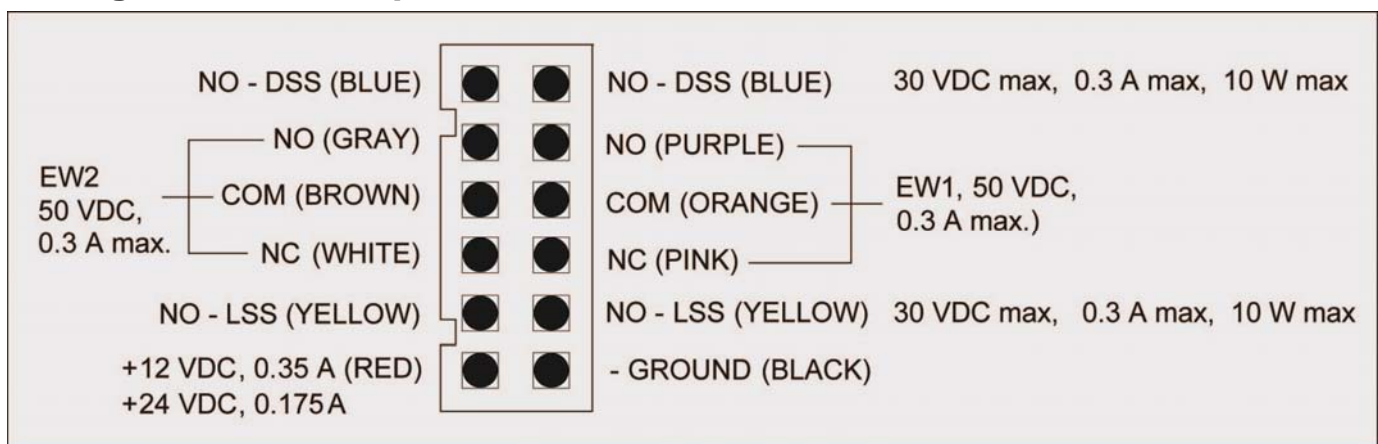

NOTE:

Ensure that wiring is connected correctly before supplying power to the MEM Lock to prevent damage to the unit.

Installation diagram

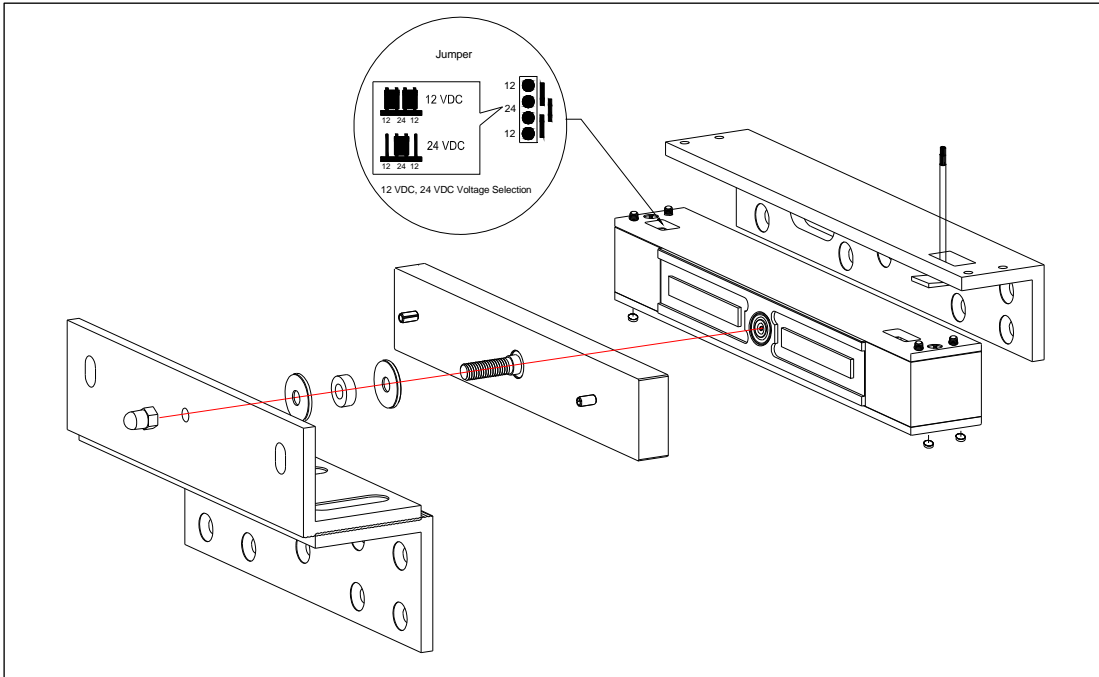

Armature Plate and Z-Bracket Installation Instructions

The armature plate (B) is screw fixed onto and through the Z-Bracket (C), with the countersunk fixing Allen screw (A). The armature plate must remain flexible to allow surface alignment with the MEM magnet face. The MEM Lock will lose holding force without this floating alignment.

1. Screw fix the Z- Bracket (C) directly to the face of the door with the self-tapping screws provided.
2. Install armature plate (B) with countersunk Allen screw (A) into and through the Z-Bracket (C). Ensure that the 2 flat washers and 1 rubber washer are in place and tighten the screw into the tapped hole of the Z-Bracket(C).
Note: The armature plate, when tightened, must remain flexible and be allowed to float as mentioned above.
3. Install the nut (D) onto the Countersunk Allen screw (A).

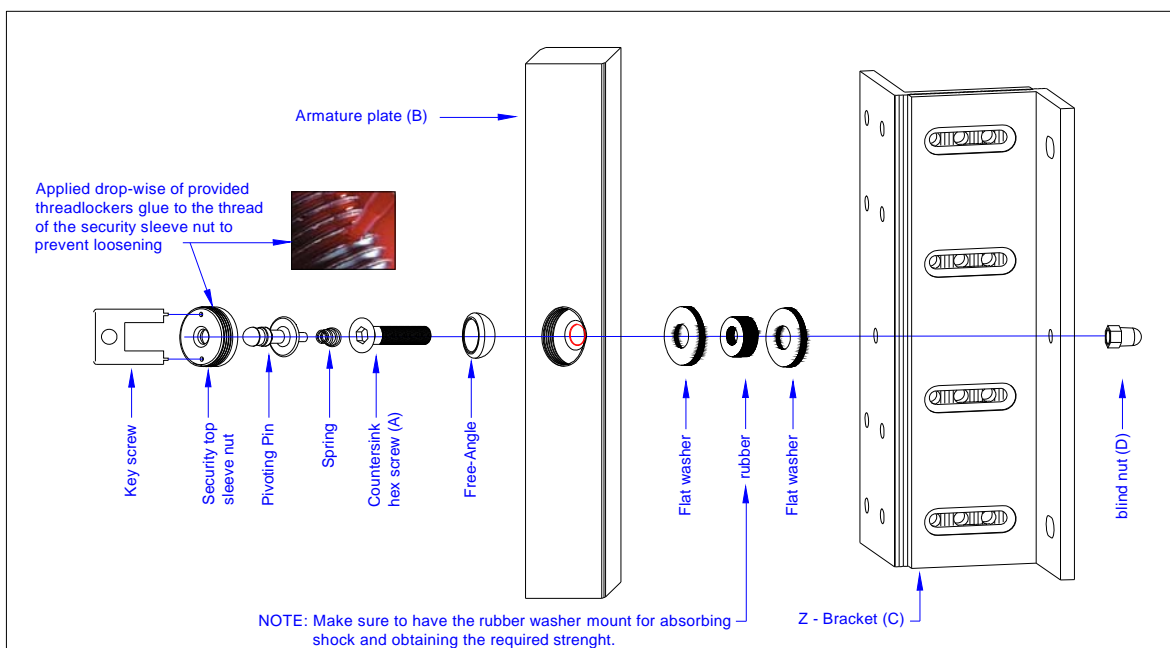

MEM2400 LED Output and Indication Status Table

Serial number	Condition	DSS	EW1	EW2	LSS	Indication on Lock (LED)
1	Power OFF Door Open					Power Off No LED Indication
2	Power OFF Door Closed					Power Off No LED Indication
3	Power On Door Open					Red LED ON
4	Power On Door Closed					Green LED ON
5	Power On Door Closed & Tampered					Green LED ON

Light feature



MEM 2400 model LED light

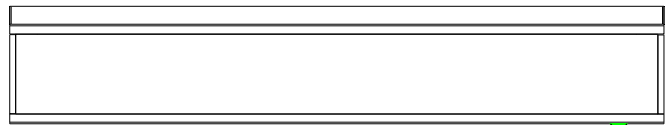

Installation Dimension

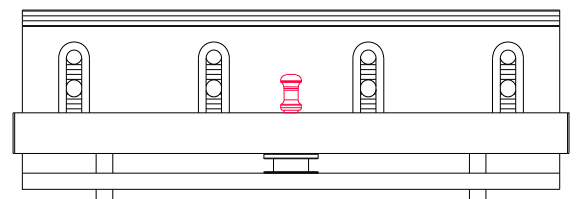
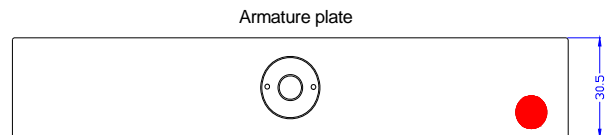
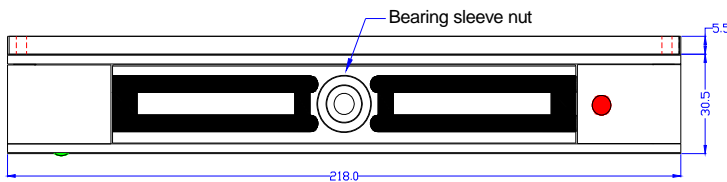

Important Safety Precaution

Using the template provided, secure the MEM2400LED MEM Lock firmly on the door frame with the provided screws and have it checked periodically for any possible screw loosening.

Maintenance

Contacting surfaces of the Mechanical Electro Magnetic Lock and Armature Plate must be kept free of contaminating materials. Surfaces should be cleaned periodically with a non-abrasive cleaner. Do not spray the MEM Lock or Armature Plate surface with any lacquer chemicals. This will cause serious problems with the release of the Armature plate from the Mechanical Electro Magnetic Lock leading to possible serious safety problems.

Trouble Shooting

PROBLEM	POSSIBLE CAUSE	SOLUTION
Door will not lock	Incorrect voltage.	Check voltage jumper setting.
	No DC voltage to lock.	Check power and loose wiring.
	Incorrect wiring connection.	Check wiring, refer to wiring instruction.
	Security top sleeve nut higher than magnet surface.	Screw fix the security top sleeve nut level with surface with the provided key screw and apply thread-locker-gluе.
Too much back pressure when power is off	Back pressure exerted on the MEM lock not allowing the magnetic lock to retract back to its original position.	Avoid applying continuous pressure on the door when closed. Realign the door.

Accessories and Applications

MEM2400L&Z to be used with MEM2400LED for inward opening doors

Adjustable L&Z Bracket for inward opening doors

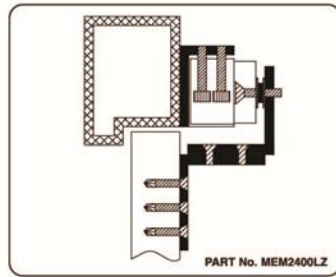
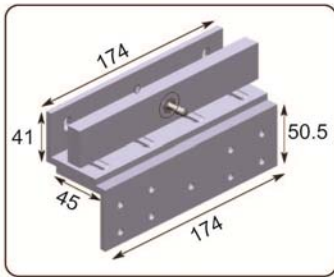

PRODUCT DESCRIPTION

The MEM L&Z Bracket is designed to be used on inward opening doors and only with the MEM2400LED model.