

# HYPERLUX White Light Illuminator

## Key Features

- Precise secondary optical technology
- The latest LED technology assures outstanding performance of LED with excellent luminous efficiency and more uniform illumination.
- Independent innovation of high efficiency power drive schemes.
- Low failure rate of products is guaranteed because of professional in-house optimized independent circuit technology widely used in our LED illuminators for more than 5 years.
- High thermal conductivity aluminum.
- Excellent thermal management not only reduces excess heat and brightness decay of LED but also ensures efficient, reliable and continuous operation of LED throughout its lifetime as 50,000 hours.
- Power factor correction technology.
- All illuminators are featured by energy saving circuit with low power consumption.
- 3 year warranty.



**HL120WH10**

## Specifications

HL120WH10	
LED type	4pcs 2W high power white light LED
Color temperature	6500-7000K
Luminous Flux	800lm
Beam angle	120°
Beam distance	10m
Voltage	DC12V/AC24V
Input CurrentV	0.8A at DC12V, 0.5A at AC24V
Power consumption	9W
Cable length	45cm (DC12V/AC24V)
Day and night switch	Auto (built-in photocell)
Mounting	Wall mounting "U" bracket
Temperature	-40°C to 50°C
Grade of protection	IP66
Color	Beige
Housing	Aluminum
Panel	High light transmittance toughened glass
Net weight	0.45kg
Gross weight	0.60kg
Unit size	84 x 84 x 80 mm
Packing size	180 x 155 x 120 mm

## Dimensions

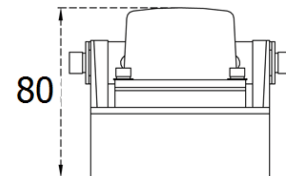

Vertical view

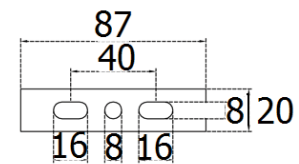

"U" wall mount bracket hole

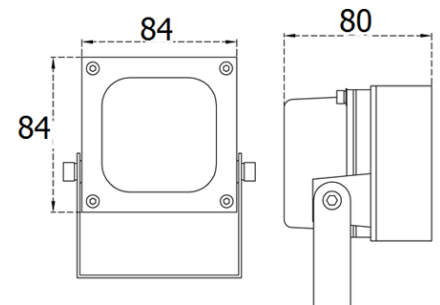

Front view

Side view