



HSB BACK BOX



For Use with Wall Mount Horns, Strobes and Horn/Strobes

HSB Includes:

- 1 - High impact plastic surface box
- 4 - 8-32 x 1.5" steel screws
- 3 - Metal washers

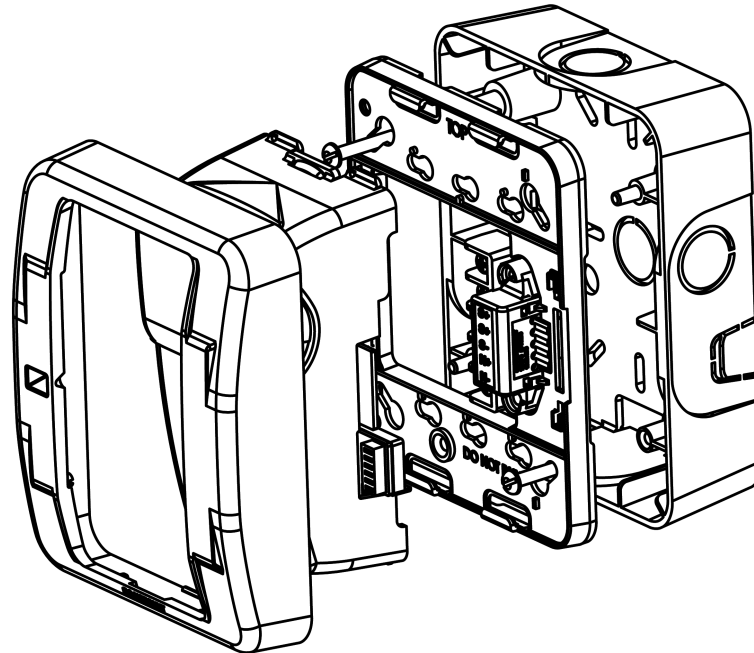

NOTICE: ♦ HSB BACK BOX IS FOR USE WITH HEH, HES AND HEC SERIES, WALL MOUNT HORNS, STROBES AND HORN/STROBES

- ♦ DO NOT OVER-TIGHTEN SCREWS OR DAMAGE TO BACK BOX MAY OCCUR
- ♦ AVAILABLE IN RED AND OFF-WHITE COLOR
- ♦ INTENDED FOR INDOOR USE ONLY
- ♦ CONDUIT AND SURFACE RACEWAY KNOCKOUTS INCLUDED
- ♦ USE REINFORCEMENT WASHERS WHEN INSTALLING CONDUIT
- ♦ UNIVERSAL MOUNTING TO SURFACE OR MOST ELECTRICAL BOXES

LIMITED WARRANTY

For a period of 36 months from the date of purchase or a maximum of 42 months from the date of manufacture, Hochiki America warrants to you the original purchaser that your appliance will be free from defects in workmanship, materials and construction under normal use and service. If a defect in workmanship, materials and construction should cause your appliance to become inoperative within the warranty period, Hochiki America will repair your appliance or furnish you with a new or rebuilt appliance without charge to you except for postage required to return the appliance to us. Hochiki America will not reimburse you for repairs or replacement parts provided by other parties. Your repaired or replacement appliance will be returned to you free of charge and it will be covered under the warranty for the balance of the warranty period.

The warranty is void if our inspection of your appliance shows that the damage or failure was caused by abuse, misuse, abnormal usage, faulty installation, improper maintenance or repairs other than those performed by us.

ANY WARRANTIES IMPLIED UNDER ANY STATE LAW INCLUDING IMPLIED WARRANTIES OF MERCHANTABILITY OR FITNESS FOR A PARTICULAR PURPOSE APPLY ONLY FOR THE WARRANTY PERIOD SPECIFIED ABOVE. PLEASE NOTE THAT SOME STATES DO NOT ALLOW LIMITATION ON HOW LONG AN IMPLIED WARRANTY LASTS. SO THE ABOVE LIMITATION MAY NOT APPLY TO YOU. HOCHIKI AMERICA WILL NOT BE LIABLE FOR ANY LOSS, DAMAGE, INCIDENTAL OR CONSEQUENTIAL DAMAGES OF ANY KIND ARISING IN CONNECTION WITH THE SALE, USE OR REPAIR OF THIS APPLIANCE. THE MAXIMUM LIABILITY OF HOCHIKI AMERICA SHALL NOT IN ANY CASE EXCEED THE PURCHASE PRICE PAID BY YOU FOR THE APPLIANCE. PLEASE NOTE THAT SOME STATES DO NOT ALLOW THE EXCLUSION OR LIMITATION OF INCIDENTAL OR CONSEQUENTIAL DAMAGES, SO THE ABOVE LIMITATION OR EXCLUSION MAY NOT APPLY TO YOU.

If a defect in workmanship, materials or construction should cause your appliance to become inoperable within the warranty period, you must return the appliance to Hochiki America postage prepaid. You must prove to the satisfaction of Hochiki America the date of purchase of your appliance. Warranty service may only be performed by Hochiki America personnel at Hochiki America's facilities in Buena Park, California. You must also pack the appliance to minimize the risk of it being damaged in transit. You must also enclose a return address. Appliances returned for warranty service should be sent to: Hochiki America Corporation, 7051 Village Drive, Suite 100, Buena Park CA 90621. If we receive an appliance in a damaged condition as the result of shipping, we will notify you and you must seek a claim with the shipper.

THIS WARRANTY GIVES YOU SPECIFIC LEGAL RIGHTS AND YOU MAY ALSO HAVE OTHER RIGHTS WHICH VARY FROM STATE TO STATE.

Important Notice:

These materials have been prepared by Hochiki America Corporation ("Hochiki America") for informational purposes only, are necessarily summary, and are not purposed to serve as legal advice and should not be used as such. Hochiki America makes no representations and warranties, express or implied, that these materials are complete and accurate, up-to-date, or in compliance with all relevant local, state and federal laws, regulations and rules. The materials do not address all legal considerations as there is inevitable uncertainty regarding interpretation of laws, regulations and rules and the application of such laws, regulations and rules to particular fact patterns. Each person's activities can differently affect the obligations that exist under applicable laws, regulations or rules. Therefore, these materials should be used only for informational purposes and should not be used as a substitute for seeking professional legal advice. Hochiki America will not be responsible for any action or failure to act in reliance upon the information contained in this material.