

x510 Series

Gigabit Ethernet Switches

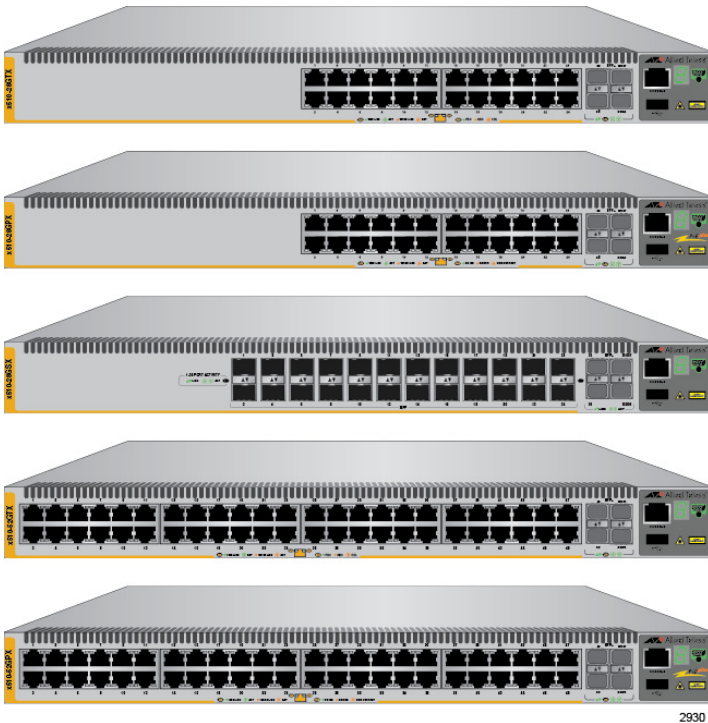

- ❑ AT-x510-28GTX
- ❑ AT-x510-28GPX
- ❑ AT-x510-28GSX
- ❑ AT-x510-28GSX-80
- ❑ AT-x510L-28GT
- ❑ AT-x510L-28GP
- ❑ AT-x510-52GTX
- ❑ AT-x510-52GPX
- ❑ AT-x510L-52GT
- ❑ AT-x510L-52GP

Installation Guide for Stand-alone Switches

Copyright © 2015 Allied Telesis, Inc.

All rights reserved. No part of this publication may be reproduced without prior written permission from Allied Telesis, Inc.

Allied Telesis and the Allied Telesis logo are trademarks of Allied Telesis, Incorporated. All other product names, company names, logos or other designations mentioned herein are trademarks or registered trademarks of their respective owners.

Allied Telesis, Inc. reserves the right to make changes in specifications and other information contained in this document without prior written notice. The information provided herein is subject to change without notice. In no event shall Allied Telesis, Inc. be liable for any incidental, special, indirect, or consequential damages whatsoever, including but not limited to lost profits, arising out of or related to this manual or the information contained herein, even if Allied Telesis, Inc. has been advised of, known, or should have known, the possibility of such damages.

Electrical Safety and Emissions Standards

This product meets the following standards.

U.S. Federal Communications Commission

Radiated Energy

Note: This equipment has been tested and found to comply with the limits for a Class A digital device pursuant to Part 15 of FCC Rules. These limits are designed to provide reasonable protection against harmful interference when the equipment is operated in a commercial environment. This equipment generates, uses, and can radiate radio frequency energy and, if not installed and used in accordance with this instruction manual, may cause harmful interference to radio communications. Operation of this equipment in a residential area is likely to cause harmful interference in which case the user will be required to correct the interference at his own expense.

Note: Modifications or changes not expressly approved of by the manufacturer or the FCC, can void your right to operate this equipment.

Industry Canada

This Class A digital apparatus complies with Canadian ICES-003.

Cet appareil numérique de la classe A est conforme à la norme NMB-003 du Canada.

RFI Emissions: FCC Class A, EN55022 Class A, EN61000-3-2, EN61000-3-3, VCCI Class A, C-TICK, CE

Warning: In a domestic environment this product may cause radio interference in which case the user may be required to take adequate measures. *⚡* E84

EMC (Immunity): EN55024

Electrical Safety: EN60950-1 (TUV), UL 60950-1 (CUL_{US})



Laser Safety

EN60825

Translated Safety Statements

Important: The  indicates that a translation of the safety statement is available in a PDF document titled “Translated Safety Statements” on the Allied Telesis website at <http://www.alliedtelesis.com/support>.

Contents

Document Conventions	14
Contacting Allied Telesis	15
Chapter 1: Overview	17
Features	18
x510 Models	18
10/100/1000 Mbps Twisted Pair Ports	18
Power Over Ethernet	18
SFP Slots	19
SFP+ Slots	19
Stacking Slots	20
LEDs	20
Installation Options	20
MAC Address Table	20
Management Software and Interfaces	20
Management Methods	21
Power Supplies	21
Front and Back Panels	22
Management Panel	26
10/100/1000Base-T Twisted Pair Ports	27
Speed	27
Duplex Mode	27
Wiring Configuration	27
Maximum Distance	28
Cable Requirements	28
Port Pinouts	28
Power Over Ethernet	29
PoE Standards	29
Powered Device Classes	29
Cable Requirements	30
Power Budget	31
Port Prioritization	32
Wiring Implementation	33
SFP+ Slots	34
Stacking SFP+ Slots	35
eco-friendly Button	36
LEDs	37
LEDs for the Twisted Pair Ports	37
LEDs for the SFP Slots	40
LEDs for the SFP+ Slots	41
LEDs for the Stacking Slots	42
Switch ID LED	43
USB Port	46
Console Port	47
Power Supplies	48
Chapter 2: Beginning the Installation	51
Reviewing Safety Precautions	52
Choosing a Site for the Switch	58
Unpacking the Switch	59

Chapter 3: Installing the Switch on a Table or in an Equipment Rack	61
Installing the Switch on a Table or Desktop.....	62
Installing the Switch in an Equipment Rack.....	63
Chapter 4: Cabling the Networking Ports	67
Cabling the Twisted Pair Ports.....	68
Installing SFP and SFP+ Transceivers	70
Installing SFP Modules in the AT-x510-28GSX and AT-x510-28GSX-80 Switches.....	71
Installing SFP and SFP+ Modules.....	74
Chapter 5: Powering On the Switch	77
Powering On the Switch.....	78
Powering On the DC Powered AT-x510-28GSX-80 Switch.....	81
Required Material and Tools.....	81
Connecting the Grounding Wire	82
Connecting the -48/-60VDC and RETURN Wires	84
Monitoring the Initialization Processes.....	89
Configuring the Switch for Stand-alone Operations.....	93
Starting a Local Management Session	93
Disabling VCStack	95
Confirming the Status of the VCStack Feature.....	97
Specifying Ports in the Command Line Interface for Stand-alone Switches.....	99
Chapter 6: Troubleshooting	101
Appendix A: Technical Specifications	105
Physical Specifications	105
Environmental Specifications.....	107
Power Specifications.....	107
Certifications	109
RJ-45 Twisted Pair Port Pinouts	109
RJ-45 Style Serial Console Port Pinouts	111

Figures

Figure 1: Front Panels of the AT-x510-28GTX, AT-x510L-28GT, and AT-x510-28GPX Switches	22
Figure 2: Front Panels of the AT-x510-28GSX, AT-x510-28GSX-80, AT-x510-52GTX, AT-x510L-52GT, AT-x510-52GPX, and AT-x510L-52GP Switches	23
Figure 3: Back Panel of the AT-x510-28GTX, AT-x510-52GTX, and AT-x510-28GSX Switches	24
Figure 4: Back Panel of the AT-x510-28GPX and AT-x510-52GPX Switches	24
Figure 5: Back Panel of the AT-x510L-28GT and AT-x510L-52GT Switches	25
Figure 6: Back Panel of the AT-x510L-28GP and AT-x510L-52GP Switches	25
Figure 7: Back Panel of the AT-x510-28GSX-80 DC Powered Switch	25
Figure 8: x510 Series Management Panel	26
Figure 9: LEDs for the 10/100/1000Base-T Ports on the AT-x510-28GTX, AT-x510L-28GT, AT-x510-52GTX, and AT-x510L-52GT Switches	37
Figure 10: LEDs for the 10/100/1000Base-T Ports on the AT-x510-28GPX, AT-x510L-28GP, AT-x510-52GPX, and AT-x510L-52GP Switches	39
Figure 11: SFP Slot LEDs on the AT-x510-28GSX and AT-x510-28GSX-80 Switches	41
Figure 12: SFP+ Slot LEDs	42
Figure 13: Switch ID LED	43
Figure 14: Switch ID LED not in Low Power Mode	44
Figure 15: Switch ID LED in Low Power Mode	45
Figure 16: Components of the x510 Series Switches	59
Figure 17: Turning the Switch Upside Down	63
Figure 18: Removing the Rubber Feet	63
Figure 19: Attaching the Equipment Rack Brackets	64
Figure 20: Attaching the Equipment Rack Brackets (Continued)	65
Figure 21: Mounting the Switch in an Equipment Rack	65
Figure 22: Removing the Dust Plug from an SFP Slot	71
Figure 23: Installing an SFP Transceiver	72
Figure 24: Removing the Dust Cover from an SFP Transceiver	72
Figure 25: Positioning the SFP Handle in the Upright Position	73
Figure 26: Connecting a Fiber Optic Cable to an SFP Transceiver	73
Figure 27: Removing the Dust Plug from an SFP+ Slot	74
Figure 28: Installing an SFP or SFP+ Transceiver	75
Figure 29: Removing the Dust Cover from an SFP or SFP+ Transceiver	75
Figure 30: Positioning the SFP or SFP+ Handle in the Upright Position	76
Figure 31: Connecting a Fiber Optic Cable to an SFP or SFP+ Transceiver	76
Figure 32: Plugging in the AC Power Cord	79
Figure 33: Ring Lug	81
Figure 34: Stripping the Stranded Grounding Wire	82
Figure 35: Attaching the Stranded Grounding Wire to the Ring Lug	82
Figure 36: Removing the Nut from the Grounding Post	83
Figure 37: Installing the Grounding Wire	83
Figure 38: Loosening the Two Captive Screws on the DC Connector	85
Figure 39: Removing the DC Connector	85
Figure 40: Loosening the Captive Screws on the DC Connector	86
Figure 41: Stripping a Stranded Power Wire	86
Figure 42: Inserting the RETURN Wire	86
Figure 43: Inserting the -48/-60VDC Wire	87
Figure 44: Sliding the DC Connector into the Switch	87
Figure 45: Securing the DC Connector to the Switch	88
Figure 46: Switch Initialization Messages	90
Figure 47: Switch Initialization Messages (Continued)	91

Figure 48: Switch Initialization Messages (Continued)	92
Figure 49: Connecting the Management Cable to the Console Port	94
Figure 50: User Exec Mode Prompt.....	95
Figure 51: SHOW STACK Command	95
Figure 52: Moving to the Global Configuration Mode	96
Figure 53: Confirmation Prompt for the NO STACK ENABLE Command	96
Figure 54: Returning to the Privileged Exec Mode	96
Figure 55: Saving the Changes with the WRITE Command.....	97
Figure 56: Status of a Stacking Slot When VCStack is Disabled.....	98
Figure 57: Status of a Stacking Slot When VCStack is Enabled	98
Figure 58: PORT Parameter in the Command Line Interface.....	99
Figure 59: RJ-45 Socket Pin Layout (Front View).....	109

Tables

Table 1: Twisted Pair Cable for the 10/100/1000Base-T Ports	28
Table 2: IEEE Powered Device Classes	30
Table 3: Twisted Pair Cable Requirements for the 10/100/1000Base-T Ports at 10 or 100Mbps	30
Table 4: Twisted Pair Cable Requirements for the 10/100/1000Base-T Ports at 1000Mbps	31
Table 5: Stacking Transceivers	35
Table 6: LEDs on the 10/100/1000Base-T Ports on the AT-x510-28GTX, AT-x510L-28GT, AT-x510-52GTX, and AT-x510L-52GT	38
Table 7: LEDs on the 10/100/1000Base-T Ports on the AT-x510-28GPX, AT-x510L-28GP, AT-x510-52GPX, and AT-x510L-52GP Switches	39
Table 8: SFP Slot LEDs on the AT-x510-28GSX and AT-x510-28GSX-80 Switches	41
Table 9: SFP+ Slot LEDs	42
Table 10: Stacking Slot LEDs	43
Table 11: Product Dimensions	105
Table 12: Product Weights	106
Table 13: Ventilation Requirements	106
Table 14: Environmental Specifications	107
Table 15: Maximum Power Consumption	107
Table 16: Input Voltages	108
Table 17: Product Certifications	109
Table 18: Pin Signals for 10 and 100 Mbps	110
Table 19: Pin Signals for 1000 Mbps	110
Table 20: RJ-45 Style Serial Console Port Pin Signals	111

Preface

This guide contains the installation instructions for the x510 Series of Layer 2+ and Basic Layer 3, Gigabit Ethernet switches. This preface contains the following sections:

- “Document Conventions” on page 14
- “Contacting Allied Telesis” on page 15

Note

This guide explains how to install the switches as stand-alone units. For instructions on how to install them in a stack configuration with Virtual Chassis Stacking (VCStack™), refer to the *x510 Series Installation Guide for Virtual Chassis Stacking*.

Document Conventions

This document uses the following conventions:

Note

Notes provide additional information.



Caution

Cautions inform you that performing or omitting a specific action may result in equipment damage or loss of data.



Warning

Warnings inform you that performing or omitting a specific action may result in bodily injury.



Warning

Laser warnings inform you that an eye and skin hazard exists due to the presence of a Class 1 laser device.

Contacting Allied Telesis

If you need assistance with this product, you may contact Allied Telesis technical support by going to the Support & Services section of the Allied Telesis web site at **www.alliedtelesis.com/support**. You can find links for the following services on this page:

- ❑ 24/7 Online Support - Enter our interactive support center to search for answers to your questions in our knowledge database, check support tickets, learn about Return Merchandise Authorizations (RMAs), and contact Allied Telesis technical experts.
- ❑ USA and EMEA phone support - Select the phone number that best fits your location and customer type.
- ❑ Hardware warranty information - Learn about Allied Telesis warranties and register your product online.
- ❑ Replacement Services - Submit an RMA request via our interactive support center.
- ❑ Documentation - View the most recent installation guides, user guides, software release notes, white papers and data sheets for your product.
- ❑ Software Updates - Download the latest software releases for your product.

For sales or corporate contact information, go to **www.alliedtelesis.com/purchase** and select your region.

Chapter 1

Overview

This chapter contains the following sections:

- “Features” on page 18
- “Front and Back Panels” on page 22
- “Management Panel” on page 26
- “10/100/1000Base-T Twisted Pair Ports” on page 27
- “Power Over Ethernet” on page 29
- “SFP+ Slots” on page 34
- “Stacking SFP+ Slots” on page 35
- “eco-friendly Button” on page 36
- “LEDs” on page 37
- “USB Port” on page 46
- “Console Port” on page 47
- “Power Supplies” on page 48

Note

This guide explains how to install the switches as stand-alone units. For instructions on how to install them in a stack configuration with Virtual Chassis Stacking (VCStack™), refer to the *x510 Series Installation Guide for Virtual Chassis Stacking*.

Features

Here are the switches and their features:

x510 Models

Here are the x510 Series switches:

- AT-x510-28GTX
- AT-x510-28GPX
- AT-x510-28GSX
- AT-x510-28GSX-80
- AT-x510L-28GT
- AT-x510L-28GP
- AT-x510-52GTX
- AT-x510-52GPX
- AT-x510L-52GT
- AT-x510L-52GP (not available in North America)

10/100/1000 Mbps Twisted Pair Ports

Here are the basic features of the 10/100/1000 Mbps twisted pair ports:

- 24 or 48 ports per switch
- 10Base-T, 100Base-TX, and 1000Base-T compliant
- IEEE 802.3u Auto-Negotiation compliant
- Auto-MDI/MDIX
- 100 meters (328 feet) maximum operating distance
- IEEE 802.3x flow control in 10/100Base-TX full-duplex mode
- IEEE 802.3x backpressure in 10/100Base-TX half-duplex mode
- IEEE 802.3ab 1000Base-T
- Jumbo frames up to 13KB
- RJ-45 connectors

Power Over Ethernet

Here are the basic features of Power over Ethernet (PoE) on the twisted pair ports on the AT-x510-28GPX, AT-x510L-28GP, AT-x510-52GPX, and AT-x510L-52GP Switches:

- Supported on ports 1 to 24 on the AT-x510-28GPX and AT-x510L-28GP Switches and ports 1 to 48 on the AT-x510-52GPX and AT-x510L-52GP Switches
- Supports PoE (15.4 watts maximum) and PoE+ (30 watts maximum) powered devices
- Supports powered device classes 0 to 4

- ❑ Maximum power budget of 370 watts for the AT-x510-28GPX and AT-x510-52GPX Switches, and 185 watts for the AT-x510L-28GP and AT-x510L-52GP Switches
- ❑ Port prioritization
- ❑ Mode A wiring

SFP Slots

Here are the basic features of the SFP slots on the AT-x510-28GSX and AT-x510-28GSX-80 Switches:

- ❑ Supports 100Base-FX and 1000Base-SX/LX SFP transceivers
- ❑ Supports single-port BiDi 1000Base-LX SFP transceivers
- ❑ Supports 1000Base-ZX SFP transceivers

Note

SFP transceivers must be purchased separately. For a list of supported transceivers, contact your Allied Telesis distributor or reseller.

SFP+ Slots

Here are the basic features of the four SFP+ slots on the switches:

- ❑ Supports 10Gbps, 10GBase-SR/LR fiber optic transceivers
- ❑ Supports 10Gbps AT-SP10TW direct connect twinax cables with SFP+ transceiver-style connectors
- ❑ Supports 1000Base-SX/LX SFP transceivers
- ❑ Supports single-port BiDi 1000Base-LX SFP transceivers
- ❑ Supports 1000Base-ZX SFP transceivers

Note

The SFP+ slots do not support 100Mbps 100Base-FX transceivers.

Note

SFP and SFP+ transceivers must be purchased separately. For a list of supported transceivers, contact your Allied Telesis distributor or reseller.

Note

SFP+ slots 27 and 28 on the 28-port switches and slots 51 and 52 on the 52-port switches are initially configured as stacking slots for the VCStack feature. If you intend to use the switch as a stand-alone unit, you must disable the VCStack feature before you can use the slots with standard SFP or SFP+ transceivers. The configuration instructions are provided later in this guide, in “Configuring the Switch for Stand-alone Operations” on page 93.

Stacking Slots

Two of the SFP+ slots can be used to create a VCStack of up to four switches. The slots support these stacking transceivers when the switch is in the stacking mode:

- AT-StackXS/1.0 Twisted Pair Transceiver - 1 meter
- AT-StackOP/0.3 Fiber Optic Transceiver - 300 meters
- AT-StackOP/9.0 Fiber Optic Transceiver - 9 kilometers

LEDs

Here are the port LEDs:

- Link/activity and duplex mode LEDs for the twisted pair ports on non-PoE switches
- Link/activity and PoE status LEDs for the twisted pair ports on PoE switches
- Link/activity LEDs for SFP and SFP+ slots
- Stack ID number LED
- eco-friendly button turns off the LEDs to conserve electricity

Installation Options

Here are the installation options for the switches:

- 19-inch equipment rack
- Desk or tabletop

MAC Address Table

Here are the basic features of the MAC address tables of the switches:

- Storage capacity of 16,000 dynamic MAC address entries
- Storage capacity of 256 static MAC address entries
- Automatic learning and aging

Management Software and Interfaces

Here are the management software and interfaces:

- AlliedWare Plus Management Software
- Command line interface
- Web browser interface

Management Methods

Here are the methods for managing the switches:

- ❑ Local management through the Console port
- ❑ Remote Telnet and Secure Shell management
- ❑ Remote HTTP and HTTPS web browser management
- ❑ SNMPv1, v2c, and v3

Power Supplies

The AT-x510-28GTX, AT-x510-28GPX, AT-x510-28GSX, AT-x510-52GTX, and AT-x510-52GPX Switches have two pre-installed AC power supplies. The AT-x510L-28GP, AT-x510L-28GT, AT-x510L-52GP, and AT-x510L-52GT Switches have one pre-installed AC power supply. The AT-x510-28GSX-80 Switch has two pre-installed DC power supplies. The DC power supply option is only available in the AT-x510-28GSX-80 Switch. The power supplies are not field-replaceable.

Front and Back Panels

The front panels of the x510 Series switches are shown in Figure 1 and Figure 2 on page 23.

AT-x510-28GTX, AT-x510L-28GT

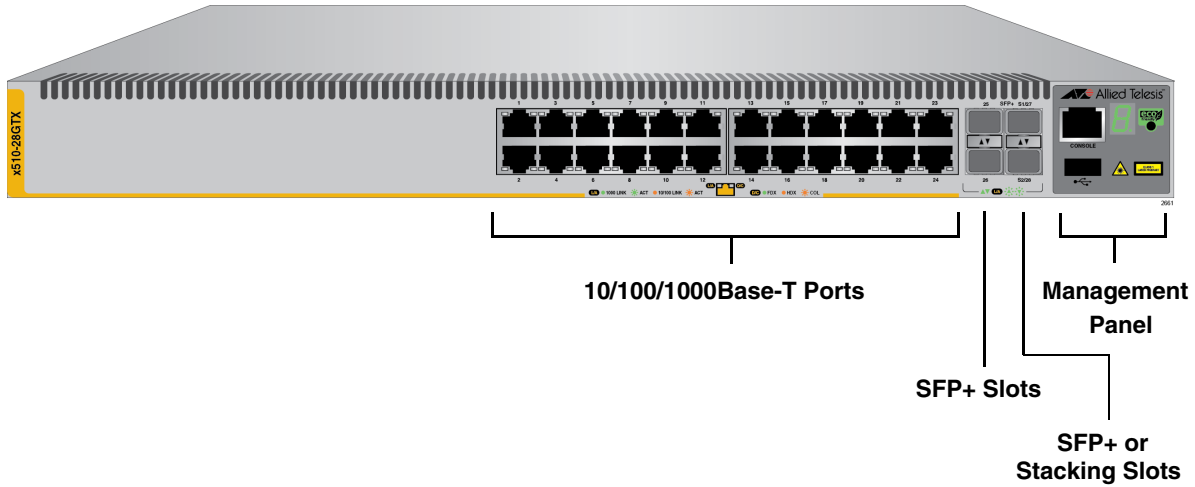

AT-x510-28GPX

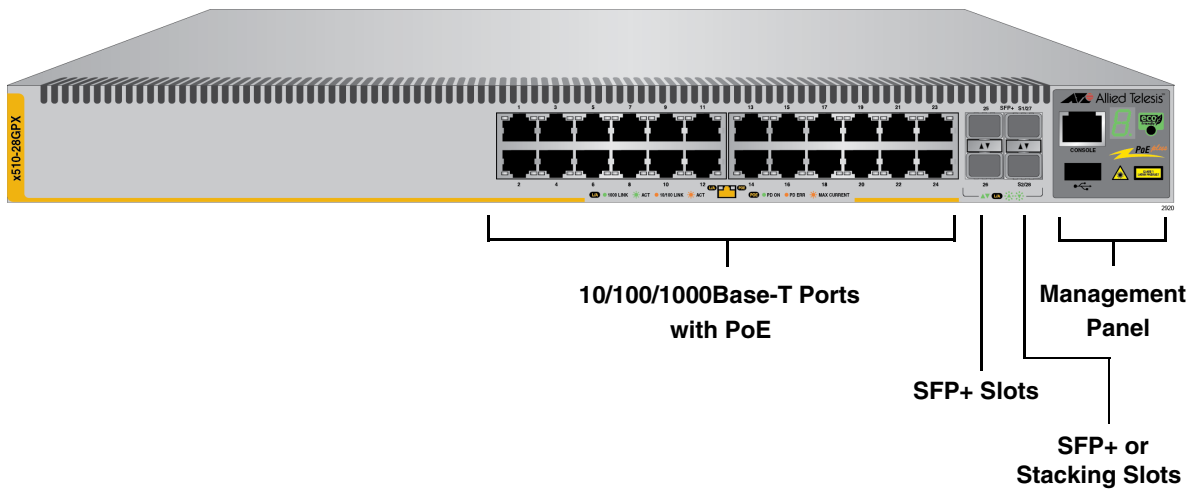
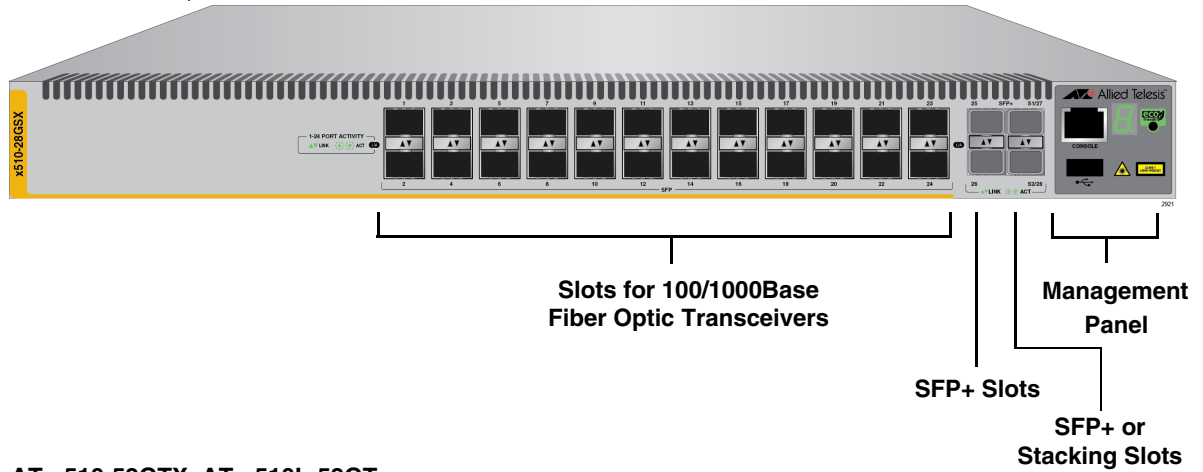
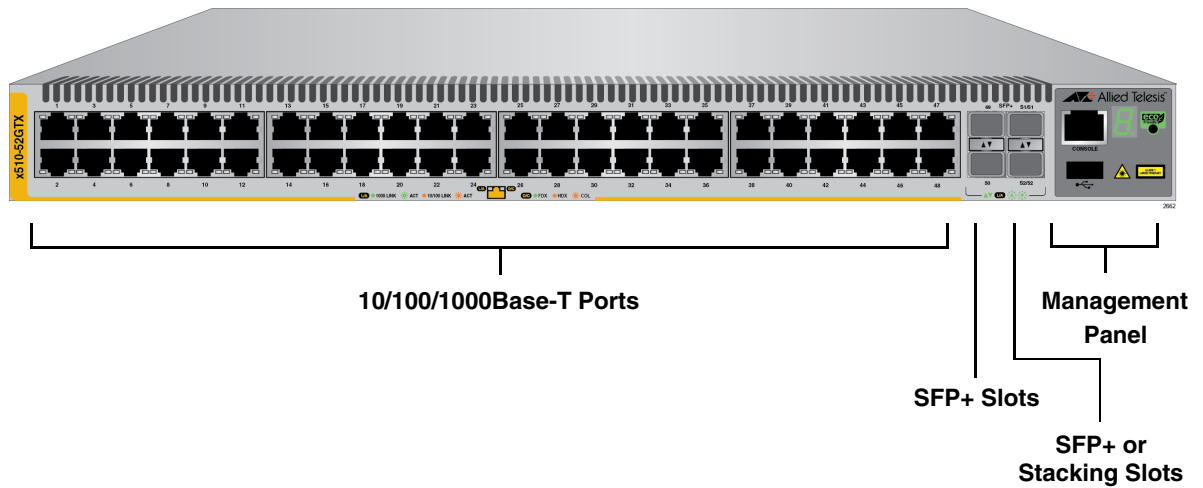

Figure 1. Front Panels of the AT-x510-28GTX, AT-x510L-28GT, and AT-x510-28GPX Switches

AT-x510-28GSX, AT-x510-28GSX-80



AT-x510-52GTX, AT-x510L-52GT



AT-x510-52GPX, AT-x510L-52GP

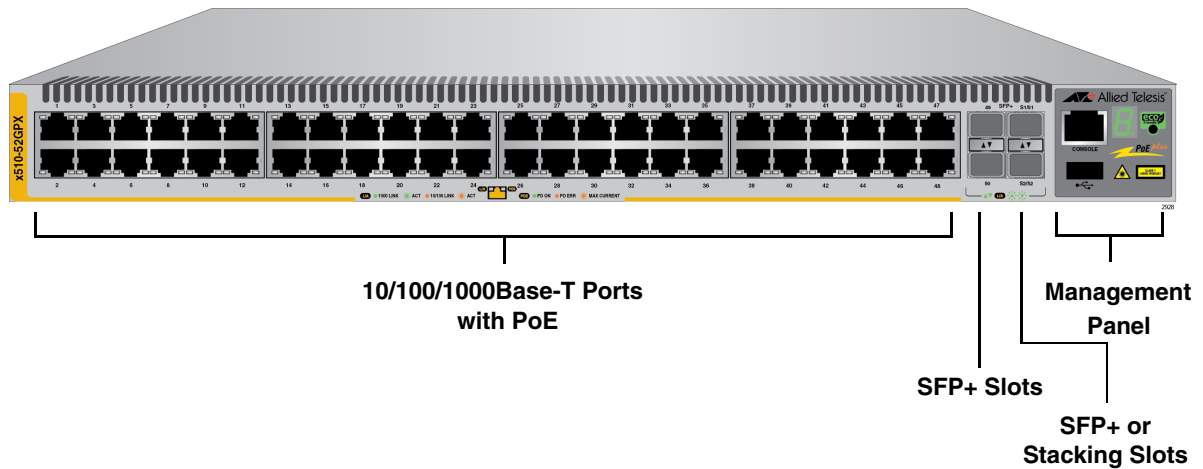

Figure 2. Front Panels of the AT-x510-28GSX, AT-x510-28GSX-80, AT-x510-52GTX, AT-x510L-52GT, AT-x510-52GPX, and AT-x510L-52GP Switches

Figure 3 shows the back panel of the AT-x510-28GTX, AT-x510-52GTX, and AT-x510-28GSX Switches.

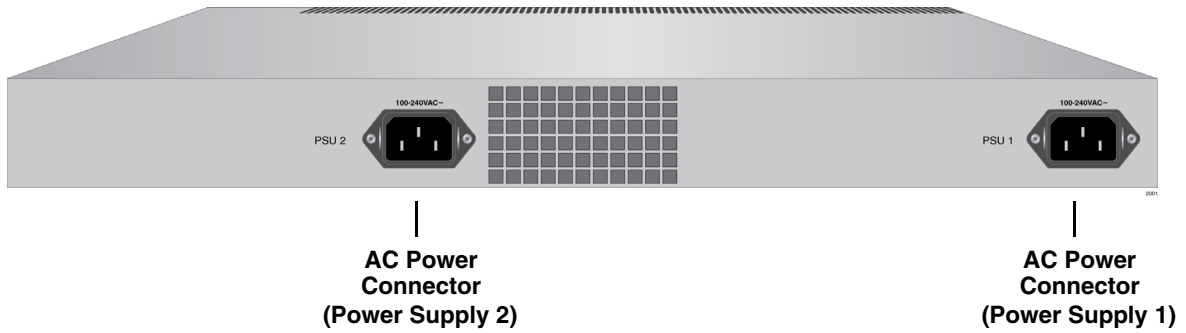

Figure 3. Back Panel of the AT-x510-28GTX, AT-x510-52GTX, and AT-x510-28GSX Switches

Figure 4 shows the back panel of the AT-x510-28GPX and AT-x510-52GPX Switches.

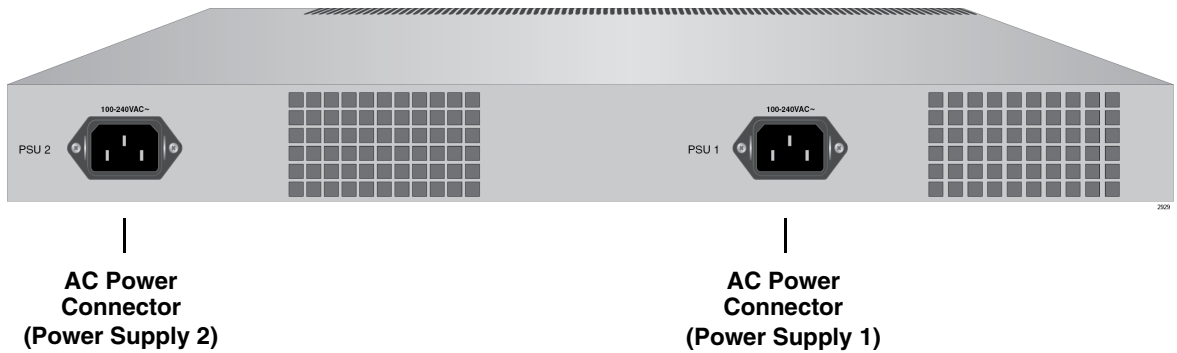

Figure 4. Back Panel of the AT-x510-28GPX and AT-x510-52GPX Switches

Figure 5 shows the back panel of the AT-x510L-28GT and AT-x510L-52GT Switches.

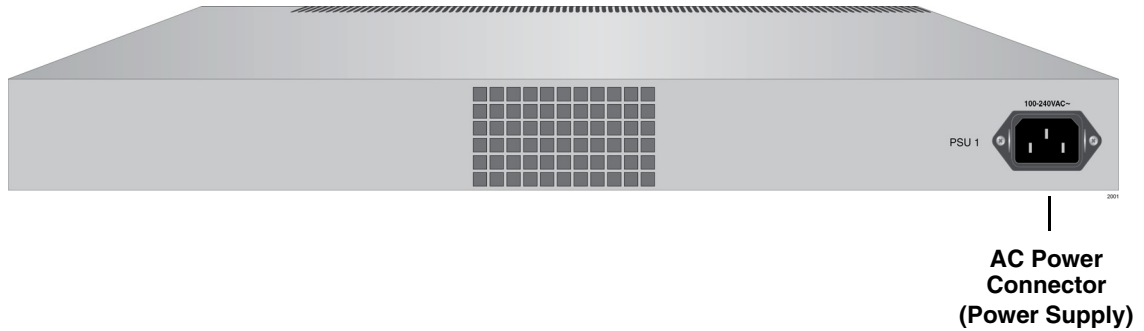

Figure 5. Back Panel of the AT-x510L-28GT and AT-x510L-52GT Switches

Figure 6 shows the back panel of the AT-x510L-28GP and AT-x510L-52GP Switches.

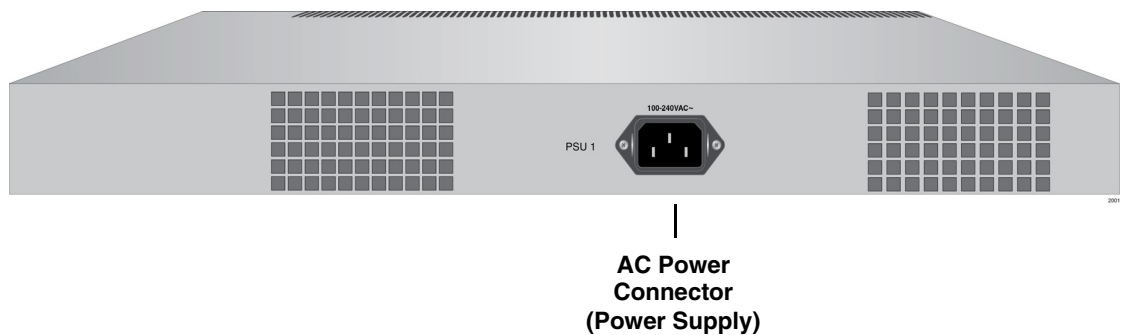

Figure 6. Back Panel of the AT-x510L-28GP and AT-x510L-52GP Switches

Figure 7 shows the back panel of the AT-x510-28GSX-80 DC powered Switch.

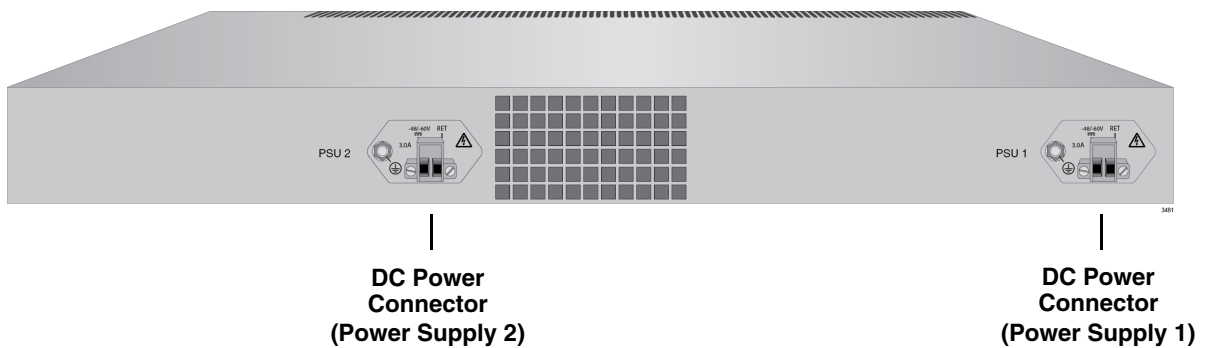

Figure 7. Back Panel of the AT-x510-28GSX-80 DC Powered Switch

Management Panel

Figure 8 identifies the components in the management panels on the x510 Series switches.

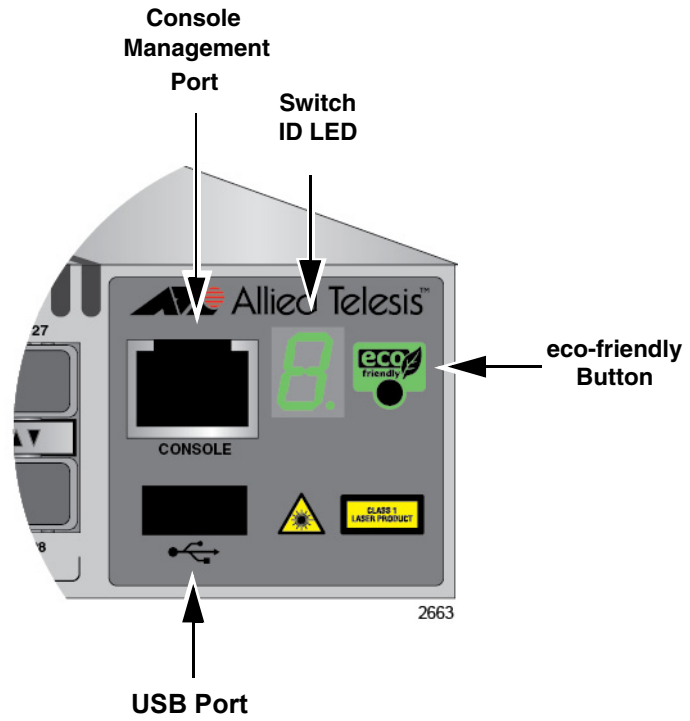

Figure 8. x510 Series Management Panel

10/100/1000Base-T Twisted Pair Ports

The AT-x510-28GTX, AT-x510-28GPX, AT-x510L-28GT, and AT-x510L-28GP Switches have 24 10/100/1000Base-T ports. The AT-x510-52GTX, AT-x510-52GPX, AT-x510L-52GT, and AT-x510L-52GP Switches have 48 10/100/1000Base-T ports.

Speed The ports can operate at 10, 100, or 1000 Mbps. The speeds may be set manually using the management software or automatically with Auto-Negotiation (IEEE 802.3u), the default setting.

Note

The ports must be set to Auto-Negotiation to function at 1000 Mbps and are not compatible with devices that are not IEEE 802.3u compliant.

Duplex Mode The twisted pair ports can operate in either half- or full-duplex mode. The duplex mode of a port, like port speed, may be set manually using the management software or automatically with Auto-Negotiation (IEEE 802.3u), the default setting.

The speed and duplex mode settings of a port may be set independently of each other. For example, a port may be configured such that its speed is set manually while its duplex mode is established through Auto-Negotiation.

Note

A switch port should not use Auto-Negotiation to set its duplex mode if it is connected to a network device that does not support Auto-Negotiation for 10 or 100 Mbps operation and has a fixed duplex mode of full-duplex. Otherwise, a duplex-mode mismatch may occur in which a switch port and a network device operate at different duplex modes. The duplex modes of switch ports that are connected to network devices that do not support Auto-Negotiation should be set manually through the management software.

Wiring Configuration The wiring configuration of a port operating at 10 or 100 Mbps can be MDI or MDI-X. The wiring configurations of a switch port and a network device connected with straight-through twisted pair cabling have to be opposite, such that one device is using MDI and the other MDI-X. For instance, a switch port has to be set to MDI-X if it is connected to a network device set to MDI.

You may set the wiring configurations of the ports manually or let the switch configure them automatically with auto-MDI/MDI-X (IEEE 802.3ab-compliant). This feature enables the switch to automatically negotiate with network devices to establish their proper settings.

The MDI and MDI-X settings do not apply when ports are operating at 1000 Mbps.

Maximum Distance

The ports have a maximum operating distance of 100 meters (328 feet).

Cable Requirements

The cable requirements of the ports are given in Table 1.

Table 1. Twisted Pair Cable for the 10/100/1000Base-T Ports

Cable Type	10Mbps	100Mbps	1000Mbps
Standard TIA/EIA 568-B-compliant Category 3 shielded or unshielded cabling with 100 ohm impedance and a frequency of 16 MHz.	Yes	Yes	No
Standard TIA/EIA 568-A-compliant Category 5 or TIA/EIA 568-B-compliant Enhanced Category 5 (Cat 5e) shielded or unshielded cabling with 100 ohm impedance and a frequency of 100 MHz.	Yes	Yes	Yes
Standard TIA/EIA 568-B-compliant Category 6 or 6a shielded cabling.	Yes	Yes	Yes

Note

For the cable requirements for the ports on the AT-x510-28GPX, AT-x510L-28GP, AT-x510-52GPX, and AT-x510L-52GP Switches for PoE devices, refer to Table 3 on page 30.

Port Pinouts

Refer to Table 18 on page 110 and Table 19 on page 110 for the port pinouts of the 10/100/1000Base-T twisted pair ports.

Power Over Ethernet

The AT-x510-28GPX, AT-x510L-28GP, AT-x510-52GPX, and AT-x510L-52GP Switches feature Power over Ethernet (PoE) on the 10/100/1000Base-T ports. PoE is used to supply power to network devices over the same twisted pair cables that carry the network traffic.

The main advantage of PoE is that it can make it easier to install a network. The selection of a location for a network device is often limited by whether there is a power source nearby. This often limits equipment placement or requires the added time and cost of having additional electrical sources installed. But with PoE, you can install PoE-compatible devices wherever they are needed without having to worry about whether there are power sources nearby.

A device that provides PoE to other network devices is referred to as *power sourcing equipment (PSE)*. The AT-x510-28GPX, AT-x510L-28GP, AT-x510-52GPX, and AT-x510L-52GP Switches act as PSE units by adding DC power to the network cable, thus functioning as a central power source for other network devices.

Devices that receive their power from a PSE are called *powered devices (PD)*. Examples include wireless access points, IP telephones, webcams, and even other Ethernet switches.

The switch automatically determines whether or not a device connected to a port is a powered device. Ports that are connected to network nodes that are not powered devices (that is, devices that receive their power from another power source) function as regular Ethernet ports, without PoE. The PoE feature remains activated on the ports, but no power is delivered to the devices.

PoE Standards

The AT-x510-28GPX, AT-x510L-28GP, AT-x510-52GPX, and AT-x510L-52GP Switches support these PoE standards:

- ❑ PoE (IEEE 802.3af): This standard provides up to 15.4 watts at the switch port to support powered devices that require up to 12.95 watts.
- ❑ PoE+ (IEEE 802.3at): This standard provides up to 30.0 watts at the switch port to support powered devices that require up to 25.5 watts.

Powered Device Classes

Powered devices are grouped into the five classes listed in Table 2 on page 30. The classes are based on the amount of power the devices require. The switches support all five classes.

Table 2. IEEE Powered Device Classes

Class	Maximum Power Output from a Switch Port	PD Power Range
0	15.4W	0.44W to 12.95W
1	4.0W	0.44W to 3.84W
2	7.0W	3.84W to 6.49W
3	15.4W	6.49W to 12.95W
4	30.0W	12.95W to 25.5W

Cable Requirements The cable requirements for ports operating at 10 or 100Mbps are given in Table 3.

Table 3. Twisted Pair Cable Requirements for the 10/100/1000Base-T Ports at 10 or 100Mbps

Cable Type	10Mbps			100Mbps		
	Non-PoE	PoE	PoE+	Non-PoE	PoE	PoE+
Standard TIA/EIA 568-B-compliant Category 3 shielded or unshielded cabling with 100 ohm impedance and a frequency of 16 MHz.	Yes	Yes	No	Yes	Yes	No
Standard TIA/EIA 568-A-compliant Category 5 shielded or unshielded cabling with 100 ohm impedance and a frequency of 100 MHz.	Yes	Yes	No	Yes	Yes	No
Standard TIA/EIA 568-B-compliant Enhanced Category 5 (Cat 5e) shielded or unshielded cabling with 100 ohm impedance and a frequency of 100 MHz.	Yes	Yes	Yes	Yes	Yes	Yes
Standard TIA/EIA 568-B-compliant Category 6 or 6a shielded cabling.	Yes	Yes	Yes	Yes	Yes	Yes

The cable requirements for ports operating at 1000Mbps are given in Table 4.

Table 4. Twisted Pair Cable Requirements for the 10/100/1000Base-T Ports at 1000Mbps

Cable Type	1000Mbps		
	Non-PoE	PoE	PoE+
Standard TIA/EIA 568-B-compliant Category 3 shielded or unshielded cabling with 100 ohm impedance and a frequency of 16 MHz.	No	No	No
Standard TIA/EIA 568-A-compliant Category 5 shielded or unshielded cabling with 100 ohm impedance and a frequency of 100 MHz.	Yes	Yes	No
Standard TIA/EIA 568-B-compliant Enhanced Category 5 (Cat 5e) shielded or unshielded cabling with 100 ohm impedance and a frequency of 100 MHz.	Yes	Yes	Yes
Standard TIA/EIA 568-B-compliant Category 6 or 6a shielded cabling.	Yes	Yes	Yes

Power Budget

The AT-x510-28GPX and AT-x510-52GPX Switches have a power budget of 370 watts. The AT-x510L-28GP and AT-x510L-52GP Switches have a power budget of 185 watts. This is the maximum amount of power the switches can provide at one time to the powered devices.

The AT-x510-28GPX and AT-x510-52GPX Switches have two power supplies. Each power supply is responsible for providing 185 watts, or half, of the power budget. Both power supplies must be connected to AC power sources for the switch to provide the full 370 watts. The power budget is reduced to 185 watts if only one power supply is connected to a power source.

The power requirements of the PoE devices determine the maximum number of devices the switch can support at one time. So long as the total power requirements of the powered devices is less than the power budget of the switch, the switch can supply power to all the devices. But if the total power requirements exceed the power budget, the switch denies power to one or more ports using a mechanism referred to as port prioritization.

To determine whether the power requirements of the PoE devices you plan to connect to the switch exceed its power budget, refer to their documentation for their power requirements and add the requirements

together. The switch should be able to power all of the devices simultaneously as long as the total is below its power budget. If the total exceeds the available power budget, you should consider reducing the number of PoE devices so that all of the devices receive power. Otherwise, the switch powers a subset of the devices, based on port prioritization.

The switch can handle different power requirements on different ports. This enables you to connect different classes of PoE equipment to the ports on the switch.

Port Prioritization

If the power requirements of the powered devices exceed the switch's power budget, the switch denies power to some ports based on a system called port prioritization. You may use this mechanism to ensure that powered devices critical to the operations of your network are given preferential treatment by the switch in the distribution of power should the demands of the devices exceed the available capacity.

There are three priority levels:

- Critical
- High
- Low

Ports set to the Critical level, the highest priority level, are guaranteed power before any of the ports assigned to the other two priority levels. Ports assigned to the other priority levels receive power only if all the Critical ports are receiving power. Ports that are connected to your most critical powered devices should be assigned to this level. If there is not enough power to support all the ports set to the Critical priority level, power is provided to the ports based on port number, in ascending order.

The High level is the second highest level. Ports set to this level receive power only if all the ports set to the Critical level are already receiving power. If there is not enough power to support all of the ports set to the High priority level, power is provided to the ports based on port number, in ascending order.

The lowest priority level is Low. This is the default setting. Ports set to this level only receive power if all of the ports assigned to the other two levels are already receiving power. As with the other levels, if there is not enough power to support all of the ports set to the Low priority level, power is provided to the ports based on port number, in ascending order.

Power allocation is dynamic. Ports supplying power to powered devices may cease power transmission if the switch's power budget is at maximum usage and new powered devices, connected to ports with higher priorities, become active.

You can use port prioritization on dual power supply PoE switches to protect your important networking devices from loss of power should one of the power supplies fail or lose power. If you limit the power requirements of the critical devices connected to a switch to less than 185 watts, the PoE power provided by a single power supply, a switch will have sufficient power to support the critical devices even if it has only one functional power supply.

Wiring Implementation

The IEEE 802.3af standard defines two methods for the delivery of DC power over twisted pair cable by a PSE, such as the switch, to PDs. These methods, known as modes A and B, identify the wires within the cable that carry the DC power from the PSE to a PD.

Twisted pair cabling typically consists of eight wires. With 10Base-T and 100Base-TX devices, the wires connected to pins 1, 2, 3, and 6 on the RJ-45 connectors carry the network traffic while the wires connected to pins 4, 5, 7, and 8 are unused. With 1000Base-T devices, all eight wires are used to carry network data.

It takes four wires to deliver DC power to a PD. With Mode A, the power is delivered on pins 1, 2, 3, and 6. These are the same pins in 10Base-T and 100Base-TX devices that carry the network data. With mode B, the power is provided over the spare wires.

The ports on the AT-x510-28GPX, AT-x510L-28GP, AT-x510-52GPX, and AT-x510L-52GP Switches deliver the power using pins 1, 2, 3, and 6, which corresponds to mode A in the IEEE 802.3af standard. Powered devices that comply with the IEEE 802.3af standard are required to support both power delivery methods. Legacy devices that do not comply with the standard will work with the switch if they are powered on pins 1, 2, 3, and 6.

SFP+ Slots

The switches have four SFP+ slots that support the following types of SFP 1000Mbps and SFP+ 10Gbps transceivers:

- ❑ 1000Base-SX/LX SFP transceivers
- ❑ Single-port BiDi 1000Base-LX SFP transceivers
- ❑ 1000Base-ZX SFP transceivers
- ❑ 10Gbps, 10GBase-SR/LR fiber optic transceivers
- ❑ 10Gbps AT-SP10TW direct connect twinax cables with SFP+ transceiver-style connectors

You may use the transceivers to connect switches to other network devices over large distances, build high-speed backbone networks between network devices, or connect high-speed devices, such as servers, to your network.

The switches support a variety of short and long distance SFP and SFP+ modules. For a list of supported SFP modules, contact your Allied Telesis representative or visit our web site.

Note

SFP+ slots 27 and 28 on the 28-port switches and slots 51 and 52 on the 52-port switches are initially configured as stacking slots for the VCStack feature. If you intend to use the switch as a stand-alone unit, you must disable the VCStack feature before you can use the slots with standard SFP or SFP+ transceivers. The configuration instructions are provided later in this guide, in “Configuring the Switch for Stand-alone Operations” on page 93.

Stacking SFP+ Slots

Two of the four SFP+ slots on the front panel of the switch can be used with special stacking transceivers to create a VCStack of up to four switches. The switches of a VCStack act as a single virtual unit. They synchronize their actions so that switching operations, like spanning tree protocols, virtual LANs, and static port trunks, span across all the units and ports. The two main advantages of stacks are:

- ❑ You can manage multiple units simultaneously, which can simplify network management.
- ❑ You have more flexibility in how you configure some of the features. For instance, a static port trunk on a stand-alone switch has to consist of ports from the same switch. In contrast, a static trunk on a stack may consist of ports from different switches in the same stack.

The slots for the stacking transceivers are SFP+ slots 27 and 28 on the 28-port switches and slots 51 and 52 on the 52-port switches.

The stacking transceivers are listed in Table 5.

Table 5. Stacking Transceivers

Transceiver Model	Cable Type	Distance
AT-StackXS/1.0	Twisted pair	1 meter
AT-StackOP/0.3	Fiber optic	300 meters
AT-StackOP/9.0	Fiber optic	9 kilometers

Note

This guide explains how to install the devices as stand-alone units. For instructions on how to install the switches in a stack, refer to the *x510 Series Installation Guide for Virtual Chassis Stacking*.

eco-friendly Button

The eco-friendly button on the front panel of the switch is used to toggle the port LEDs on or off. You might turn off the LEDs to conserve electricity when you are not monitoring the device. You can also toggle the LEDs with the ECOFRIENDLY LED and NO ECOFRIENDLY LED commands in the Global Configuration mode of the command line interface. The switch is said to be operating in a low power mode when the LEDs are turned off.

Operating the switch in the low power mode with the LEDs turned off does not interfere with the network operations of the device.

The management software on the switch has a command that blinks the LEDs so that you can quickly and easily identify a specific unit among the devices in an equipment rack. It is the FINDME command. The command works on the switch even if you turned off the LEDs with the eco-friendly button or NO ECOFRIENDLY LED command.

The Switch ID LED is always on, but it displays different information depending on whether the LEDs are on or off. When the LEDs are on, the ID LED displays the ID number of the switch. When the switch is operating in the low power mode with the LEDs off, the ID LED indicates whether the switch is a stand-alone unit or the master or member switch of a VCStack, as detailed in Figure 15 on page 45.

Note

Before checking or troubleshooting the network connections to the ports on the switch, you should always check to be sure that the LEDs are on by either pressing the eco-friendly button or issuing the ECOFRIENDLY LED and NO ECOFRIENDLY LED commands in the Global Configuration mode of the command line interface.

LEDs

Here are descriptions of the LEDs.

LEDs for the Twisted Pair Ports

The twisted pair ports on the AT-x510-28GTX, AT-x510L-28GT, AT-x510-52GTX, and AT-x510L-52GT Switches have two LEDs that display link, activity and duplex mode information. The LEDs are shown in Figure 9.

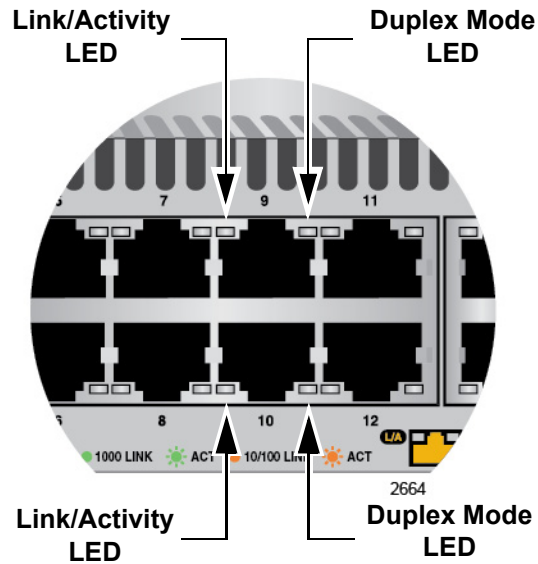

Figure 9. LEDs for the 10/100/1000Base-T Ports on the AT-x510-28GTX, AT-x510L-28GT, AT-x510-52GTX, and AT-x510L-52GT Switches

The LEDs are described in Table 6 on page 38.

Table 6. LEDs on the 10/100/1000Base-T Ports on the AT-x510-28GTX, AT-x510L-28GT, AT-x510-52GTX, and AT-x510L-52GT

LED	State	Description
Link/ Activity LED	Solid Green	A port has established a 1000 Mbps link to a network device.
	Flashing Green	A port is transmitting or receiving data at 1000 Mbps.
	Solid Amber	A port has established a 10 or 100 Mbps link to a network device.
	Flashing Amber	A port is transmitting or receiving data at 10 or 100 Mbps.
	Off	A port has not established a link with another network device or the LEDs are turned off. To turn on the LEDs, use the eco-friendly button.
Duplex Mode LED	Green	A port is operating in full-duplex mode.
	Amber	A port is operating in half-duplex mode at 10 or 100 Mbps. (Half-duplex mode does not apply to 1000 Mbps operation.)
	Flashing Amber	Collisions are occurring on a port operating at 10 or 100 Mbps.

The twisted pair ports on the AT-x510-28GPX, AT-x510L-28GP, AT-x510-52GPX, and AT-x510L-52GP Switches have two LEDs that display link, activity and PoE information. The LEDs are shown in Figure 10 on page 39.

Note

The duplex mode information for the ports on the AT-x510-28GPX, AT-x510L-28GP, AT-x510-52GPX, and AT-x510L-52GP Switches can be viewed with the management software.

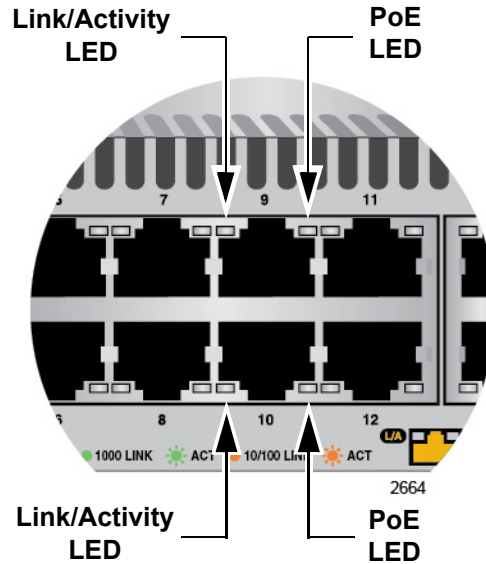

Figure 10. LEDs for the 10/100/1000Base-T Ports on the AT-x510-28GPX, AT-x510L-28GP, AT-x510-52GPX, and AT-x510L-52GP Switches

The LEDs are described in Table 7.

Table 7. LEDs on the 10/100/1000Base-T Ports on the AT-x510-28GPX, AT-x510L-28GP, AT-x510-52GPX, and AT-x510L-52GP Switches

LED	State	Description
Link/ Activity LED	Solid Green	A port has established a 1000 Mbps link to a network device.
	Flashing Green	A port is transmitting or receiving data at 1000 Mbps.
	Solid Amber	A port has established a 10 or 100 Mbps link to a network device.
	Flashing Amber	A port is transmitting or receiving data at 10 or 100 Mbps.
	Off	A port has not established a link with another network device or the LEDs are turned off. To turn on the LEDs, use the eco-friendly button.

Table 7. LEDs on the 10/100/1000Base-T Ports on the AT-x510-28GPX, AT-x510L-28GP, AT-x510-52GPX, and AT-x510L-52GP Switches

LED	State	Description
PoE	Green	The switch is detecting a powered device (PD) on the port and is delivering power to it.
	Solid Amber	The switch has shut down PoE+ on the port because of a fault condition.
	Flashing Amber	The switch is detecting a PD on the port, but is not delivering power to it because the maximum power budget has been reached.
	Off	This LED state can result from the following conditions: <ul style="list-style-type: none"> ❑ The port is not connected to a PD. ❑ The PD is powered off. ❑ The port is disabled in the management software. ❑ PoE is disabled on the port. ❑ The LEDs on the Ethernet line cards are turned off. To turn on the LEDs, use the eco-friendly button.

LEDs for the SFP Slots

The LEDs for the SFP slots on the AT-x510-28GSX and AT-x510-28GSX-80 Switches are located between the slots, as shown in Figure 11 on page 41. Each SFP slot has one LED. The left-hand LED is for the top slot, and the right-hand LED is for the bottom slot.

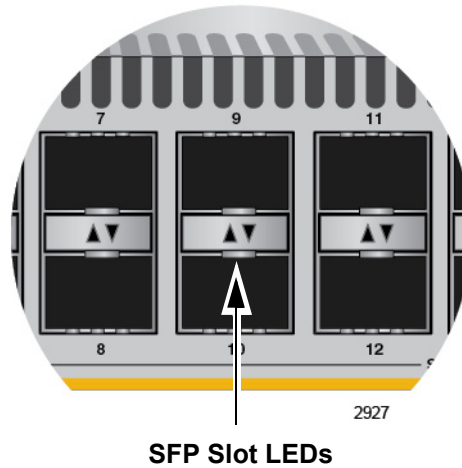

Figure 11. SFP Slot LEDs on the AT-x510-28GSX and AT-x510-28GSX-80 Switches

The LEDs are described in Table 8.

Table 8. SFP Slot LEDs on the AT-x510-28GSX and AT-x510-28GSX-80 Switches

LED	State	Description
Link/Activity	Off	The slot is empty, the SFP transceiver has not established a link to a network device, or the LEDs are turned off. To turn on the LEDs, use the eco-friendly button.
	Solid green	The SFP transceiver has established a link at 10 Mbps, 1000 Mbps or 10 Gbps to a network device.
	Flashing green	The SFP transceiver is receiving or transmitting packets to a network device.

LEDs for the SFP+ Slots

The LEDs for the SFP+ slots are located between the slots, as shown in Figure 12 on page 42. Each SFP+ slot has one LED. The left-hand LED is for the top slot, and the right-hand LED is for the bottom slot.

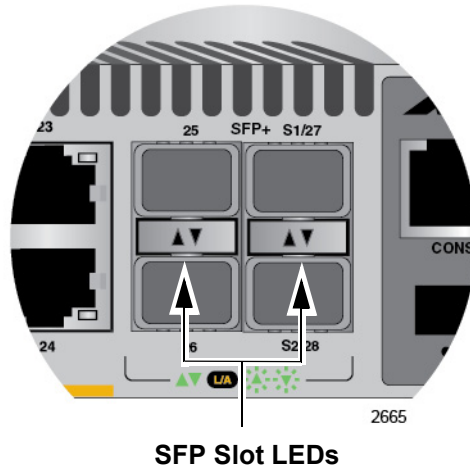

Figure 12. SFP+ Slot LEDs

The LEDs are described in Table 9.

Table 9. SFP+ Slot LEDs

LED	State	Description
Link/Activity	Off	The slot is empty, the SFP or SFP+ transceiver has not established a link to a network device, or the LEDs are turned off. To turn on the LEDs, use the eco-friendly button.
	Solid green	The SFP or SFP+ transceiver has established a link at 1000 Mbps or 10 Gbps to a network device.
	Flashing green	The SFP+ transceiver is receiving or transmitting packets to a network device at 10 Gbps. (The LED does not flash for activity at 1000 Mbps.)

LEDs for the Stacking Slots

SFP+ slots 27 and 28 on the 28-port switches and slots 51 and 52 on the 52-port switches may be used as stacking slots to build a VCStack of up to four switches. For background information, refer to the *x510 Series Installation Guide for Virtual Chassis Stacking*. Table 10 on page 43 defines the LED states when the slots contain stacking transceivers.

Table 10. Stacking Slot LEDs

LED	State	Description
Link/Activity	Off	The slot is empty, the stacking transceiver has not established a link to a network device, or the LEDs are turned off. To turn on the LEDs, use the eco-friendly button.
	Solid green	The stacking transceiver has established a 10 Gbps link to another switch in the stack.
	Flashing green	The stacking transceiver is receiving or transmitting packets.

Switch ID LED

The Switch ID LED, shown in Figure 13, displays the ID number of the switch. A stand-alone switch has the ID number 0. Switches in a VCStack have the numbers 1 to 4. Chapter 5, “Powering On the Switch” on page 77 has the procedure for verifying and, if necessary, changing the ID number of the switch.

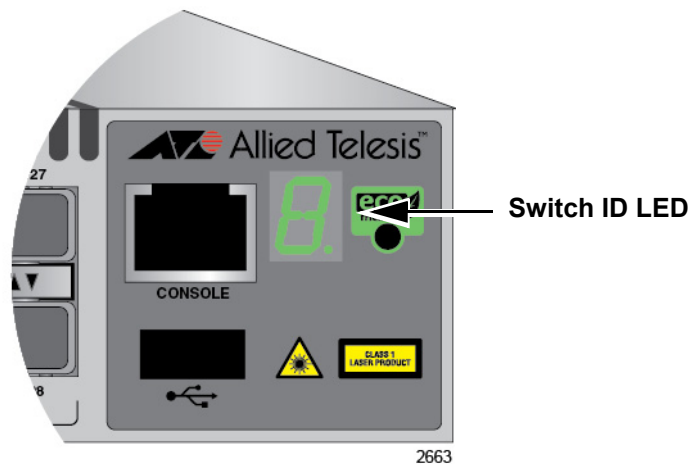

Figure 13. Switch ID LED

The states of the LED when the switch is not operating in the low power mode are shown in Figure 14 on page 44.

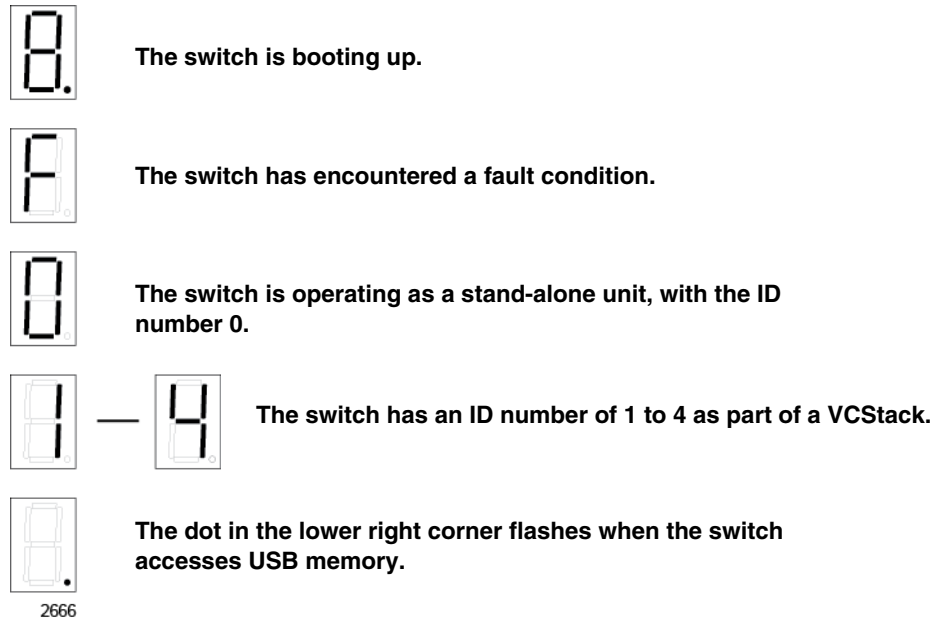

Figure 14. Switch ID LED not in Low Power Mode

The switch displays the letter “F” for fault on the ID LED if it encounters one of the following problems:

- A cooling fan has failed.
- The input voltage on one or both of the power supplies is outside the normal operating range.
- The internal temperature of the switch has exceeded the normal operating range and the switch may shut down.

Note

You can use the `SHOW SYSTEM ENVIRONMENT` command in the command line interface to identify the source of the problem.

The states of the LED when the switch is operating in the low power mode are shown in Figure 15 on page 45.



The switch is the master switch of a VCStack.



The switch is operating as a stand-alone unit.



The switch is a member switch of a VCStack.

2667

Figure 15. Switch ID LED in Low Power Mode

USB Port

The management panel has a USB port. You may use the port to store configuration files on flash drives and to restore configuration files to switches whose settings have been lost or corrupted, or to quickly configure replacement units. You may also use the port and flash drives to update the management firmware on the switches.

The port is USB2.0 compatible.

Console Port

The Console port is used to establish a management session with the switch to configure its features and parameter settings. This type of management uses serial RS-232 and is commonly referred to as local or out-of-band management because it is not conducted over your network. To perform local management, you must be at the location of the switch and must use the management cable included with the switch.

To establish a local management session with the switch, connect a terminal or a personal computer with a terminal emulation program to the Console port, which has an RJ-45 style (8P8C) connector, using the provided management cable. The cable has RJ-45 RJ-style (8P8C) and DB-9 (D-sub 9-pin) connectors.

The Console port is set to the following specifications:

- Default baud rate: 9600 bps (Range is 9600 to 115200 bps)
- Data bits: 8
- Parity: None
- Stop bits: 1
- Flow control: None

Note

These settings are for a DEC VT100 or ANSI terminal, or an equivalent terminal emulation program.

Power Supplies

Please review the following information concerning the power supplies:

- ❑ The AT-x510-28GTX, AT-x510-28GPX, AT-x510-28GSX, AT-x510-52GTX, and AT-x510-52GPX Switches have two pre-installed AC power supplies.
- ❑ The AT-x510L-28GT, AT-x510L-28GP, AT-x510L-52GT, and AT-x510L-52GP Switches have one pre-installed AC power supply.
- ❑ The AT-x510-28GSX-80 Switch has two pre-installed DC power supplies. The DC power supply option is only available in the AT-x510-28GSX-80 Switch.
- ❑ On all switches except the AT-x510L-28GT, AT-x510L-28GP, AT-x510L-52GT, and AT-x510L-52GP Switches, the pre-installed AC or DC power supplies have separate connectors on the back panel. You can protect the network operations of the switch from a power circuit failure by connecting the power supplies to different circuits.
- ❑ The non-PoE AT-x510-28GTX, AT-x510-28GSX, and AT-x510-52GTX Switches require only one power supply for full operations. The second power supply provides power redundancy. It protects against interruptions to network operations in the event one power supply loses power or fails. Power redundancy is available only when both AC or DC connectors on the switch are connected to power sources.
- ❑ The PoE AT-x510-28GPX and AT-x510-52GPX Switches also require only one power supply for network operations, excluding PoE. The switches can continue to operate even if one power supply fails or loses power.
- ❑ The second power supply in the PoE AT-x510-28GPX and AT-x510-52GPX Switches increases the amount of power for PoE. The power budget for powered devices is 185 watts when one power supply is operating and 370 watts when both power supplies are operating. For further information, refer to “Power Budget” on page 31.
- ❑ The power supplies are not field replaceable.
- ❑ For the DC powered AT-x510-28GSX-80 Switch, the DC supply wires should be routed from a DC load center containing appropriate overcurrent branch protection for each DC feed, as required by the cognizant local electrical authority.

Refer to “Technical Specifications” on page 105 for the input voltage ranges.



Warning

Power cord is used as a disconnection device. To de-energize equipment, disconnect the power cord. ⚡ E3



Warning

This unit might have more than one power cord. To reduce the risk of electric shock, disconnect all power cords before servicing the unit. ⚡ E30

Note

The switches are powered on or off by connecting or disconnecting the power cords.

Chapter 2

Beginning the Installation

The chapter contains the following sections:

- “Reviewing Safety Precautions” on page 52
- “Choosing a Site for the Switch” on page 58
- “Unpacking the Switch” on page 59

Reviewing Safety Precautions

Please review the following safety precautions before beginning the installation procedure.

Note

Safety statements that have the  symbol are translated into multiple languages in the *Translated Safety Statements* document at www.alliedtelesis.com/support.



Warning

Class 1 Laser product.  L1



Warning

Do not stare into the laser beam.  L2



Warning

Do not look directly at the fiber optic ends or inspect the cable ends with an optical lens.  L6



Warning

To prevent electric shock, do not remove the cover. No user-serviceable parts inside. This unit contains hazardous voltages and should only be opened by a trained and qualified technician. To avoid the possibility of electric shock, disconnect electric power to the product before connecting or disconnecting the LAN cables.  E1



Warning

Do not work on equipment or cables during periods of lightning activity.  E2



Warning

Power cord is used as a disconnection device. To de-energize equipment, disconnect the power cord. ⚡ E3



Warning

Class I Equipment. This equipment must be earthed. The power plug must be connected to a properly wired earth ground socket outlet. An improperly wired socket outlet could place hazardous voltages on accessible metal parts. ⚡ E4

Note

Only one grounding post on the DC powered AT-x510-28GSX-80 Switch should be connected to the building protective earth. The second grounding post should not be used. Allied Telesis recommends using the grounding post for power supply 1 (PSU 1).

Note

Pluggable Equipment. The socket outlet shall be installed near the equipment and shall be easily accessible. ⚡ E5



Caution

Air vents must not be blocked and must have free access to the room ambient air for cooling. ⚡ E6



Warning

Operating Temperatures. All the switches are designed for a maximum ambient temperature of 45° degrees C. ⚡ E52

Note

All Countries: Install product in accordance with local and National Electrical Codes. ⚡ E8



Warning

As a safety precaution, install a circuit breaker with a minimum value of 10 Amps between the equipment and the DC power source.

Always connect the wires to the LAN equipment first before connecting the wires to the circuit breaker. Do not work with HOT leads to avoid the danger of physical injury from electrical shock. Always be sure that the circuit breaker is in the OFF position before connecting the wires to the breaker. ⚡ E9



Warning

When installing this equipment, always ensure that the power supply ground connection is installed first and disconnected last. ⚡ E11



Warning

Only trained and qualified personnel are allowed to install or replace this equipment. ⚡ E14



Caution

Circuit Overloading: Consideration should be given to the connection of the equipment to the supply circuit and the effect that overloading of circuits might have on overcurrent protection and supply wiring. Appropriate consideration of equipment nameplate ratings should be used when addressing this concern. ⚡ E21



Caution

Risk of explosion if battery is replaced by an incorrect type. Replace only with the same or equivalent type recommended by the manufacturer. Dispose of used batteries according to the manufacturer's instructions.

Attention: Le remplacement de la batterie par une batterie de type incorrect peut provoquer un danger d'explosion. La remplacer uniquement par une batterie du même type ou de type équivalent recommandée par le constructeur. Les batteries doivent être éliminées conformément aux instructions du constructeur. ⚡ E22



Warning

Mounting of the equipment in the rack should be such that a hazardous condition is not created due to uneven mechanical loading. ⚡ E25

Note

Use dedicated power circuits or power conditioners to supply reliable electrical power to the device. ⚡ E27



Caution

The chassis may be heavy and awkward to lift. Allied Telesis recommends that you get assistance when mounting the chassis in an equipment rack. ⚡ E28



Warning

This unit might have more than one power cord. To reduce the risk of electric shock, disconnect all power cords before servicing the unit. ⚡ E30



Warning

The power input must be provided by a SELV source only, per IEC60950. Do not connect to a centralized DC battery bank. ⚡ E31

Note

If installed in a closed or multi-unit rack assembly, the operating ambient temperature of the rack environment may be greater than the room ambient temperature. Therefore, consideration should be given to installing the equipment in an environment compatible with the manufacturer's maximum rated ambient temperature (T_{mra}). ⚡ E35



Caution

Installation of the equipment in a rack should be such that the amount of air flow required for safe operation of the equipment is not compromised. *⌘* E36



Warning

Reliable earthing of rack-mounted equipment should be maintained. Particular attention should be given to supply connections other than direct connections to the branch circuits (e.g., use of power strips). *⌘* E37



Warning

Circuit breaker is used as a disconnection device. To de-energize the equipment, shut down the circuit breaker and then disconnect the input wire. *⌘* E38



Warning

To reduce the risk of electric shock, the PoE ports on this product must not connect to cabling that is routed outside the building where this device is located. *⌘* E40



Caution

The unit does not contain serviceable components. Please return damaged units for servicing. *⌘* E42



Warning

When you remove an SFP module from this product, the case temperature of the SFP may exceed 40° C (158° F). Exercise caution when handling with unprotected hands. *⌘* E43



Warning

This equipment must be installed in a Restricted Access location. ⚡ E45



Warning

An SFP transceiver can be damaged by static electricity. Be sure to observe all standard electrostatic discharge (ESD) precautions, such as wearing an antistatic wrist strap, to avoid damaging the transceiver. ⚡ E86



Caution

You have to reset the switch to disable the VCStack feature. Some network traffic may be lost if the device is already connected to a live network. ⚡ E89



Warning

Switches should not be stacked on top of one another on a table or desktop because that could present a personal safety hazard if you need to move or replace switches. ⚡ E91

Choosing a Site for the Switch

Observe these requirements when planning the installation of the switch.

- If you plan to install the switch in an equipment rack, check to be sure that the rack is safely secured so that it will not tip over. Devices in a rack should be installed starting at the bottom, with the heavier devices near the bottom of the rack.
- If you plan to install the switch on a table, check to be sure that the table is level and stable.
- The power outlet should be located near the switch and be easily accessible.
- The site should allow for easy access to the ports on the front of the switch, so that you can easily connect and disconnect cables, and view the port LEDs.
- The site should allow for adequate air flow around the unit and through the cooling vents on the front and rear panels. (The ventilation direction in units that have a cooling fan is from front to back, with the fan on the back panel drawing the air out of the unit.)
- The site should not expose the switch to moisture or water.
- The site should be a dust-free environment.
- The site should include dedicated power circuits or power conditioners to supply reliable electrical power to the network devices.
- Do not install the switch in a wiring or utility box because it will overheat and fail from inadequate airflow.
- The rubber feet on the bottom of the switch should be left on for table or desktop installation.



Warning

Switches should not be stacked on top of one another on a table or desktop because that could present a personal safety hazard if you need to move or replace switches. *see* E91

Unpacking the Switch

Figure 16 lists the items that come with the switch. If any item is missing or damaged, contact your Allied Telesis sales representative for assistance.

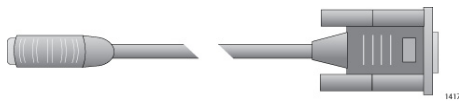

One 2 m (6.6 ft) local management cable with RJ-45 (8P8C) and DB-9 (D-sub 9-pin) connectors

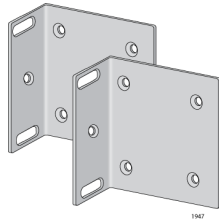

Two rack mounting brackets



One or two regional AC power cords:

AT-x510L-28GT, AT-x510L-52GP, AT-x510L-52GT,
AT-x510L-52GP: 1 each

AT-x510-28GTX, AT-x510-28GPX,
AT-x510-28GSX, AT-x510-52GTX,
AT-x510-52GPX: 2 each



Eight bracket screws

Figure 16. Components of the x510 Series Switches

Note

The DC powered AT-x510-28GSX-80 Switch does not come with the two regional AC power cords.

Note

You should retain the original packaging material in the event you need to return the unit to Allied Telesis.

Chapter 3

Installing the Switch on a Table or in an Equipment Rack

The procedures in this chapter are:

- “Installing the Switch on a Table or Desktop” on page 62
- “Installing the Switch in an Equipment Rack” on page 63

Installing the Switch on a Table or Desktop

This section contains the procedure for installing the switch on a table.

Note

The rubber feet on the bottom of the chassis should be left on for table installation.



Warning

Switches should not be stacked on top of one another on a table or desktop because that could present a personal safety hazard if you need to move or replace switches. ⚡ E91

To install the chassis on a table, perform the following procedure:

1. Review the procedure in “Choosing a Site for the Switch” on page 58 to verify that the selected site is suitable for the unit.
2. Check to be sure that the table is strong enough to support the weight of the switch.
3. Lift the chassis onto the table.
4. Check to be sure that all of the appropriate components are included in the shipping container. Refer to “Unpacking the Switch” on page 59.

After placing the switch on the table or desktop, go to Chapter 4, “Cabling the Networking Ports” on page 67 to connect the network cables to the ports on the switch.

Installing the Switch in an Equipment Rack

This procedure requires the following items:

- Eight bracket screws (included with the switch)
- Two equipment rack brackets (included with the switch)
- Flat-head screwdriver (not provided)
- Cross-head screwdriver (not provided)
- Four standard equipment rack screws (not provided)

Installation guidelines may be found in “Choosing a Site for the Switch” on page 58. Here is the procedure for installing the switch in a 19-inch equipment rack.



Caution

The chassis may be heavy and awkward to lift. Allied Telesis recommends that you get assistance when mounting the chassis in an equipment rack. *aw* E28

1. Place the unit upside down on a level, secure surface.

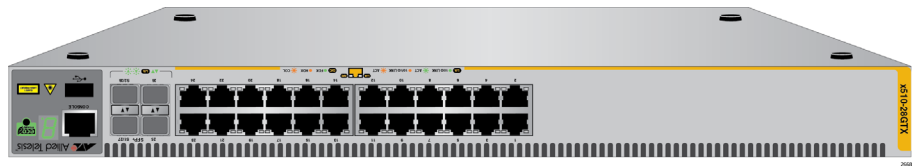

Figure 17. Turning the Switch Upside Down

2. Using a flat-head screwdriver, pry the rubber feet from the bottom of the switch. Refer to Figure 18.

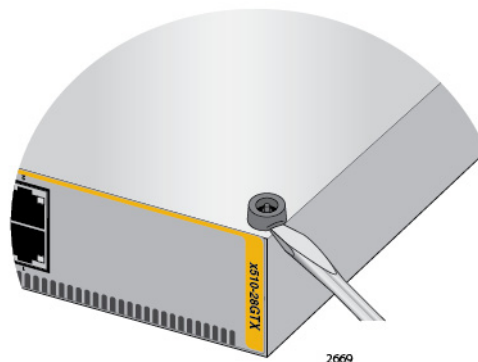

Figure 18. Removing the Rubber Feet

3. Turn the switch over.
4. Attach the two rack mount brackets to the sides of the switch using the eight bracket screws included with the unit. Figure 19 and Figure 20 on page 65 illustrate the four possible bracket positions.

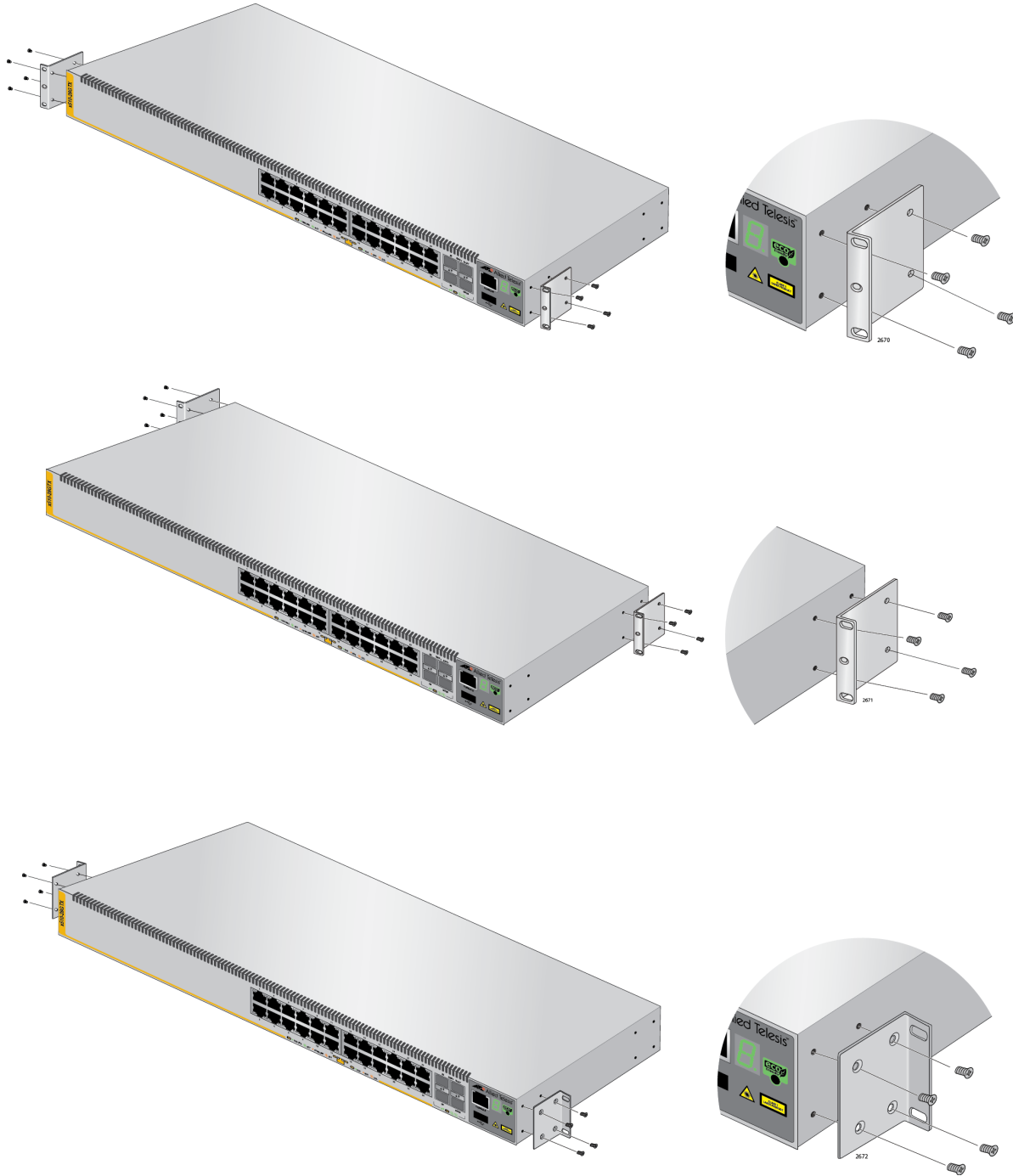

Figure 19. Attaching the Equipment Rack Brackets



Figure 20. Attaching the Equipment Rack Brackets (Continued)

5. While another person holds the switch in the equipment rack, secure it using standard equipment rack screws (not provided), as shown in Figure 21.



Figure 21. Mounting the Switch in an Equipment Rack

Go to Chapter 4, “Cabling the Networking Ports” on page 67, to connect the network cables to the ports on the switch.

Chapter 4

Cabling the Networking Ports

This chapter contains the following procedures:

- “Cabling the Twisted Pair Ports” on page 68
- “Installing SFP and SFP+ Transceivers” on page 70

Cabling the Twisted Pair Ports

Here are the guidelines to cabling the 10/100/1000Base-T twisted pair ports:

- ❑ The cable specifications for the 10/100/1000Base-T twisted pair ports are listed in Table 1 on page 28.
- ❑ The connectors on the cables should fit snugly into the ports, and the tabs should lock the connectors into place.
- ❑ The default setting for the wiring configurations of the ports is auto-MDI/MDI-X. The default setting is appropriate for switch ports that are connected to 10/100Base-TX network devices that also support auto-MDI/MDI-X.
- ❑ The default auto-MDI/MDI-X setting is not appropriate for switch ports that are connected to 10/100Base-TX network devices that do not support auto-MDI/MDI-X and have a fixed wiring configuration. For switch ports connected to those types of network devices, you should disable auto-MDI/MDI-X and set the wiring configurations manually.
- ❑ The appropriate MDI/MDI-X setting for a switch port connected to a 10/100Base-TX network device with a fixed wiring configuration depends on the setting of the network device and whether the switch and network device are connected with straight-through or crossover cable. If you are using straight-through twisted pair cable, the wiring configurations of a port on the switch and a port on a network device must be opposite each other, such that one port uses MDI and the other MDI-X. For example, if a network device has a fixed wiring configuration of MDI, you must disable auto-MDI/MDI-X on the corresponding switch port and manually set it to MDI-X. If you are using crossover twisted pair cable, the wiring configurations of a port on the switch and a port on a network device must be the same.
- ❑ The default speed setting for the ports is Auto-Negotiation. This setting is appropriate for ports connected to network devices that also support Auto-Negotiation.
- ❑ The default speed setting of Auto-Negotiation is not appropriate for ports connected to 10/100Base-TX network devices that do not support Auto-Negotiation and have fixed speeds. For those switch ports, you should disable Auto-Negotiation and set the port's speed manually to match the speeds of the network devices.
- ❑ The 10/100/1000Base-T ports must be set to Auto-Negotiation, the default setting, to operate at 1000Mbps.
- ❑ The default duplex mode setting for the ports is Auto-Negotiation. This setting is appropriate for ports connected to network devices that also support Auto-Negotiation for duplex modes.

- ❑ The default duplex mode setting of Auto-Negotiation is not appropriate for ports connected to network devices that do not support Auto-Negotiation and have a fixed duplex mode. You should disable Auto-Negotiation on those ports and set their duplex modes manually to avoid the possibility of duplex mode mismatches. A switch port using Auto-Negotiation defaults to half-duplex if it detects that the end node is not using Auto-Negotiation, which can result in a mismatch if the end node is operating at a fixed duplex mode of full-duplex.
- ❑ Do not attach cables to ports of static or LACP port trunks until after you have configured the trunks on the switch. Otherwise, the ports will form network loops that can adversely affect network performance.

Installing SFP and SFP+ Transceivers

This section contains guidelines and procedures for installing SFP and SFP+ transceivers. The installation procedures are listed here:

- ❑ “Installing SFP Modules in the AT-x510-28GSX and AT-x510-28GSX-80 Switches” on page 71
- ❑ “Installing SFP and SFP+ Modules” on page 74

Here are general installation guidelines for SFP and SFP+ transceivers:

- ❑ SFP and SFP+ transceivers are hot-swappable. You may install them while the chassis is powered on.
- ❑ Your Allied Telesis sales representative can provide you with a list of supported transceivers for the units.
- ❑ The operational specifications and fiber optic cable requirements of the transceivers are provided in the documents included with the devices.
- ❑ You should install a transceiver before connecting the fiber optic cable.
- ❑ Fiber optic transceivers are dust sensitive. Always keep the plug in the optical bores when a fiber optic cable is not installed, or when you store the transceiver. When you do remove the plug, keep it for future use.
- ❑ Unnecessary removal and insertion of a transceiver can lead to premature failure.



Warning

An SFP transceiver can be damaged by static electricity. Be sure to observe all standard electrostatic discharge (ESD) precautions, such as wearing an antistatic wrist strap, to avoid damaging the transceiver. *see* E86

Note

SFP+ slots 27 and 28 on the 28-port switches and slots 51 and 52 on the 52-port switches are initially configured as stacking slots for the VCStack feature. If you intend to use the switch as a stand-alone unit, you must disable the VCStack feature before you can use the slots with standard SFP or SFP+ transceivers. For instructions, refer to Chapter 5, “Powering On the Switch” on page 77.

Installing SFP Modules in the AT-x510-28GSX and AT-x510-28GSX-80 Switches

To install SFP transceivers in slots 1 to 24 of the AT-x510-28GSX or AT-x510-28GSX-80 Switches, perform the following procedure:

1. Remove the dust plug from a transceiver slot on the switch. Refer to Figure 22.

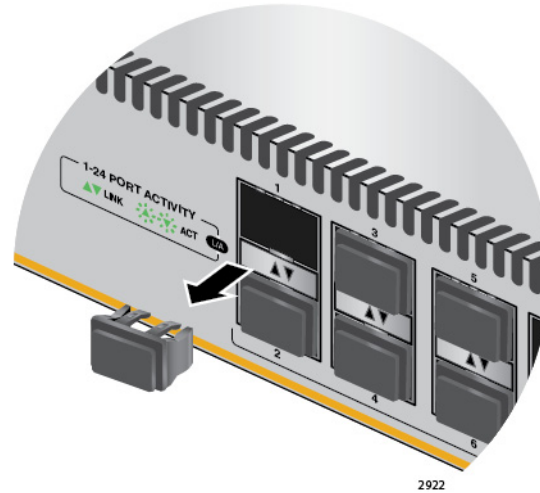

Figure 22. Removing the Dust Plug from an SFP Slot

2. Remove the transceiver from its shipping container and store the packaging material in a safe location.
3. If you are installing the transceiver in a top slot, position the transceiver with the Allied Telesis label facing up. If you are installing the transceiver in a bottom slot, position the transceiver with the label facing down.
4. Slide the transceiver into the slot until it clicks into place, as shown in Figure 23 on page 72.

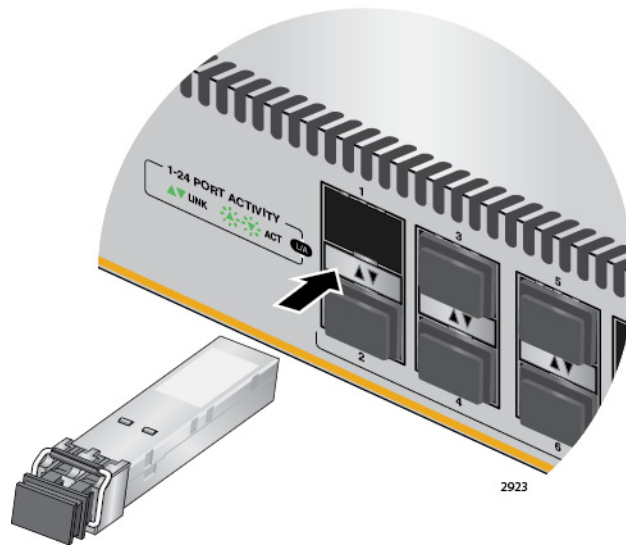

Figure 23. Installing an SFP Transceiver

Note

If you are ready to attach the fiber optic cable to the transceiver, continue with the next step. Otherwise, repeat Step 1 through Step 4 to install the remaining SFP transceivers in the switch.

5. Remove the dust cover from the transceiver, as shown in Figure 24.

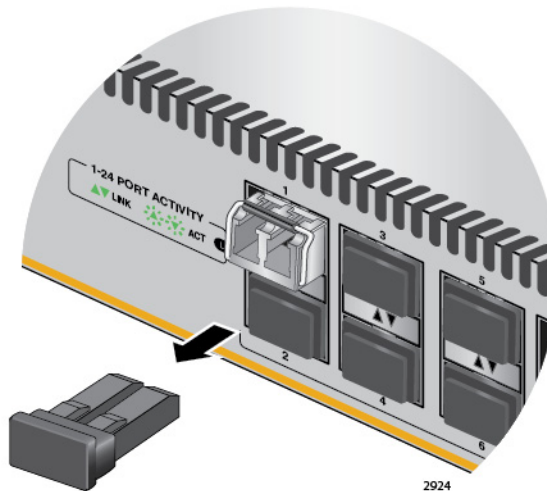

Figure 24. Removing the Dust Cover from an SFP Transceiver

6. Verify the position of the handle on the SFP transceiver. If the transceiver is in a top slot, the handle should be in the upright position, as shown in Figure 25 on page 73. If the transceiver is in a bottom slot, the handle should be in the down position.

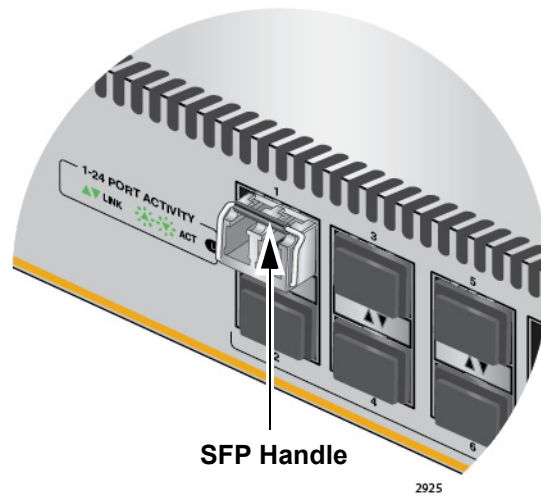

Figure 25. Positioning the SFP Handle in the Upright Position

7. Connect the fiber optic cable to the transceiver, as shown in Figure 26. The connector on the cable should fit snugly into the port, and the tab should lock the connector into place.

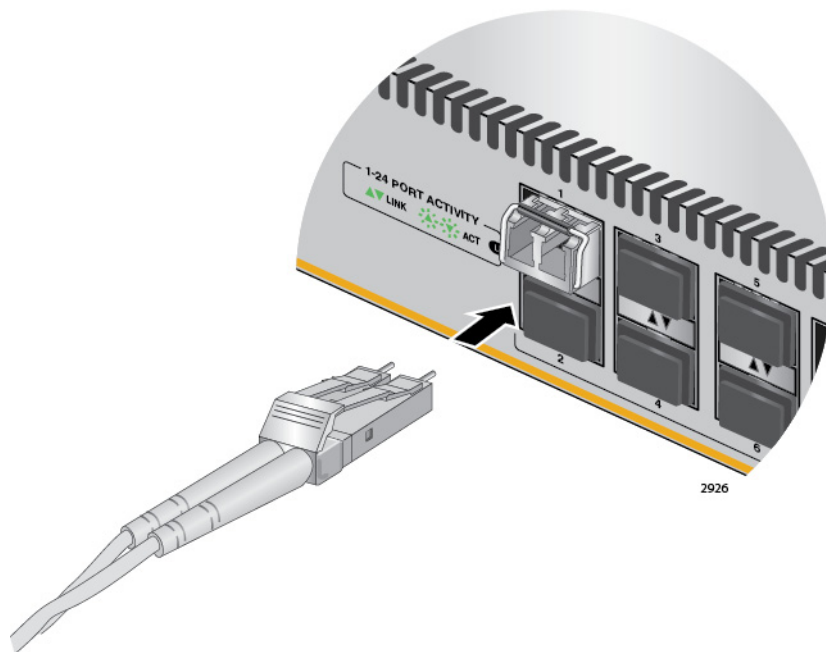

Figure 26. Connecting a Fiber Optic Cable to an SFP Transceiver

8. Repeat this procedure to install additional transceivers.

Installing SFP and SFP+ Modules

To install SFP and SFP+ transceivers in slots 27 and 28 of the 28-port switches and slots 51 and 52 of the 52-port switches, perform the following procedure:

1. Remove the dust plug from a transceiver slot on the switch. Refer to Figure 27.

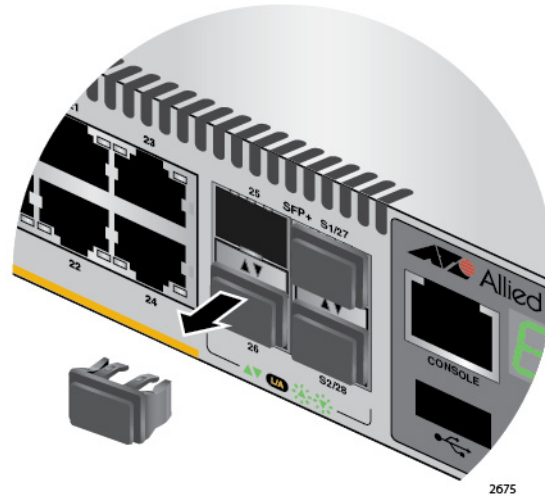

Figure 27. Removing the Dust Plug from an SFP+ Slot

2. Remove the transceiver from its shipping container and store the packaging material in a safe location.
3. If you are installing the transceiver in a top slot, position the transceiver with the Allied Telesis label facing up. If you are installing the transceiver in a bottom slot, position the transceiver with the label facing down.
4. Slide the transceiver into the slot until it clicks into place, as shown in Figure 28 on page 75.

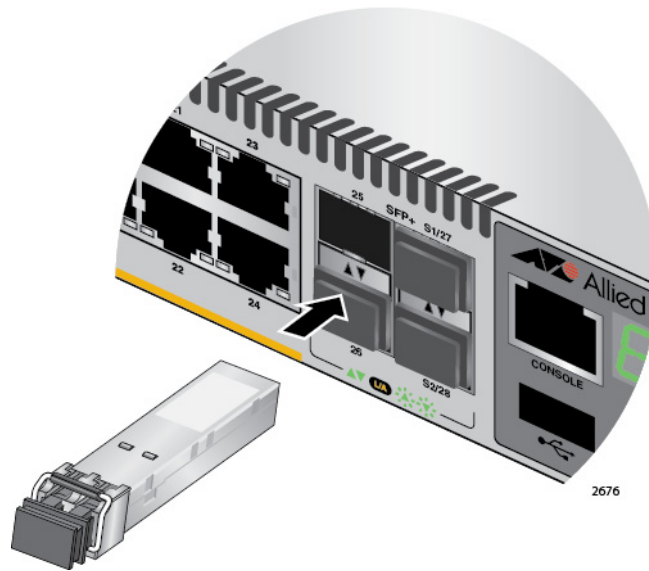

Figure 28. Installing an SFP or SFP+ Transceiver

Note

If you are ready to attach the fiber optic cable to the transceiver, continue with the next step. Otherwise, repeat Step 1 through Step 4 to install the remaining SFP or SFP+ transceivers in the switch.

5. Remove the dust cover from the transceiver, as shown in Figure 29.

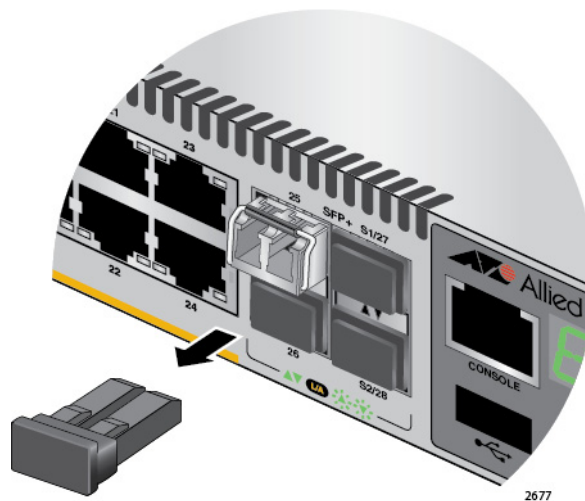

Figure 29. Removing the Dust Cover from an SFP or SFP+ Transceiver

6. Verify the position of the handle on the SFP transceiver. If the transceiver is in a top slot, the handle should be in the upright position, as shown in Figure 30. If the transceiver is in a bottom slot, the handle should be in the down position.

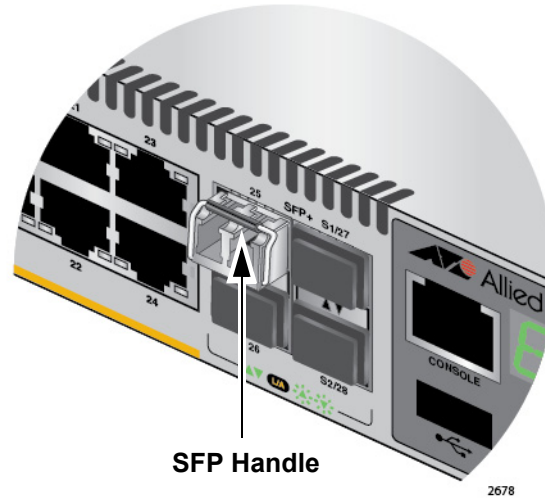

Figure 30. Positioning the SFP or SFP+ Handle in the Upright Position

7. Connect the fiber optic cable to the transceiver, as shown in Figure 31. The connector on the cable should fit snugly into the port, and the tab should lock the connector into place.

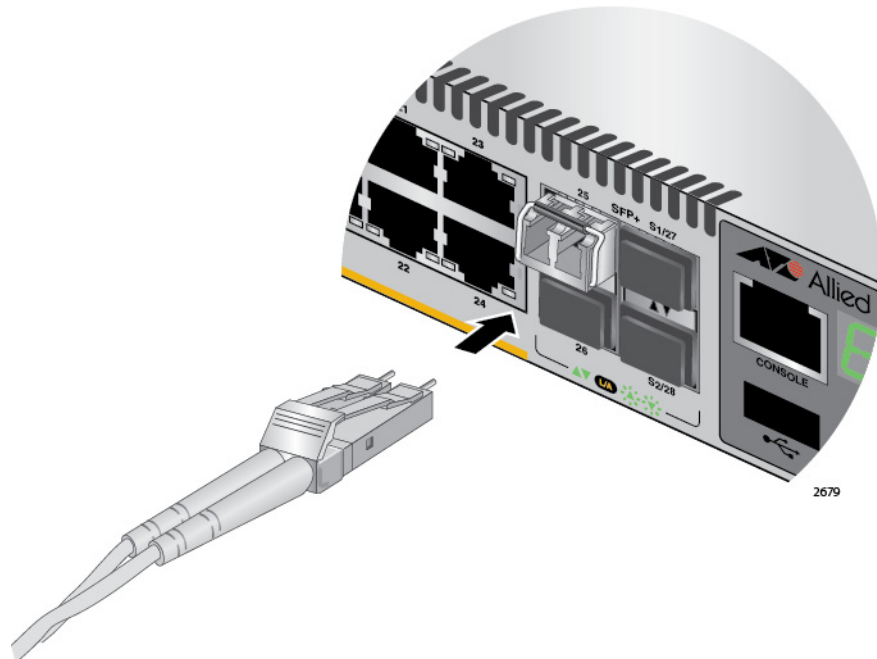

Figure 31. Connecting a Fiber Optic Cable to an SFP or SFP+ Transceiver

8. Repeat this procedure to install additional transceivers.

Chapter 5

Powering On the Switch

This chapter contains the following procedures:

- ❑ “Powering On the Switch” on page 78
- ❑ “Powering On the DC Powered AT-x510-28GSX-80 Switch” on page 81
- ❑ “Monitoring the Initialization Processes” on page 89
- ❑ “Configuring the Switch for Stand-alone Operations” on page 93
- ❑ “Specifying Ports in the Command Line Interface for Stand-alone Switches” on page 99

Powering On the Switch

Note

For instructions on powering on the AT-x510-28GSX-80, refer to “Powering On the DC Powered AT-x510-28GSX-80 Switch” on page 81.

To power on the switch, connect the power cords to the connectors on the back panels and to the appropriate power sources. The AT-x510-28GTX, AT-x510-28GPX, AT-x510-28GSX, AT-x510-52GTX, and AT-x510-52GPX models have two power supplies with separate connectors. The AT-x510L-28GT, AT-x510L-28GP, AT-x510L-52GT and AT-x510L-52GP models have one power supply with one connector.



Figure 32. Plugging in the AC Power Cord

Consider the following items as you power on the switch:

- ❑ Connecting the two power cords to power sources that are on different circuits will provide power redundancy to the switch in the event a circuit fails.
- ❑ Refer to “Power Specifications” on page 107 for the power specifications of the switches.



Warning

Power cord is used as a disconnection device. To de-energize equipment, disconnect the power cord. ⚡ E3

Note

Pluggable Equipment. The socket outlet shall be installed near the equipment and shall be easily accessible. ⚡ E5

Powering On the DC Powered AT-x510-28GSX-80 Switch

This section contains the procedure for powering on the DC power supplies in the AT-x510-28GSX Switch.



Warning

This equipment must be installed in a Restricted Access location. ⚡
E45

Required Material and Tools

The procedure requires the following material:

- One 12 AWG stranded grounding wire. The standard color for the wire is green with a yellow stripe.
- One 16 AWG minimum stranded power wire for the -48/-60VDC connection. The standard color for the wire is red.
- One 16 AWG minimum stranded power wire for the RETURN connection. The standard color for the wire is black.
- One ring lug suitable for a M4/#8 stud and 12 AWG wire. An example of a ring lug is shown in Figure 33.



Figure 33. Ring Lug

Note

The grounding and power wires should be stranded wires. Do not use solid wires.

This procedure requires the following tools:

- Crimping tool
- 7mm wrench
- 7mm, 15 in-lb torque wrench (optional)
- 3mm (0.125 in.) flat-head screwdriver
- 3mm (0.125 in.), 5 in-lb torque, flat-head screwdriver (optional)

Note

You must provide the wires, ring lug, and tools. They are not included with the switch.

Connecting the Grounding Wire

To connect the grounding wire to the grounding post, perform the following procedure:



Warning

When installing this equipment, always ensure that the power supply ground connection is installed first and disconnected last. ⚡ E11

Note

Only one grounding post on the switch should be connected to the building protective earth. The second grounding post should not be used. Allied Telesis recommends using the grounding post for power supply 1 (PSU 1).

1. Strip an adequate amount of insulation from one end of the ground cable, for the ring lug. The amount may vary depending on the type of ring lug, but 6.5mm (0.25 in.) is typically sufficient. Refer to Figure 34.

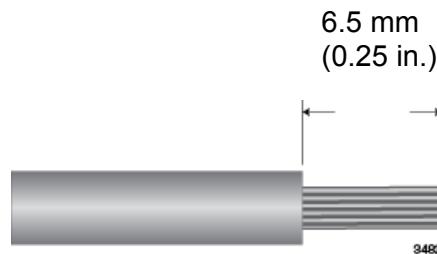

Figure 34. Stripping the Stranded Grounding Wire

2. Insert the grounding wire into the ring lug and use a crimping tool to secure it. Refer to Figure 35.

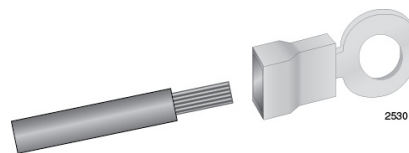

Figure 35. Attaching the Stranded Grounding Wire to the Ring Lug

3. Use a 7mm wrench to remove the top nut from the grounding post on the power supply. Refer to Figure 36 on page 83.

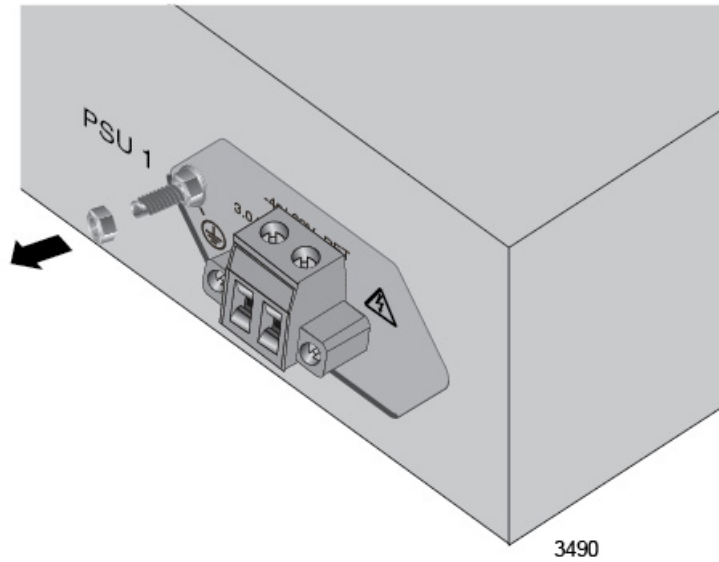

Figure 36. Removing the Nut from the Grounding Post

Note

Remove only the top nut from the grounding post. If necessary, use a second 7mm wrench to hold the bottom nut still while removing the top nut.

4. Attach the grounding lug and wire to the grounding post and secure them with the nut removed in Step 3 and a 7mm wrench. Allied Telesis recommends tightening the nut to 15 in-lbs. Refer to Figure 37.

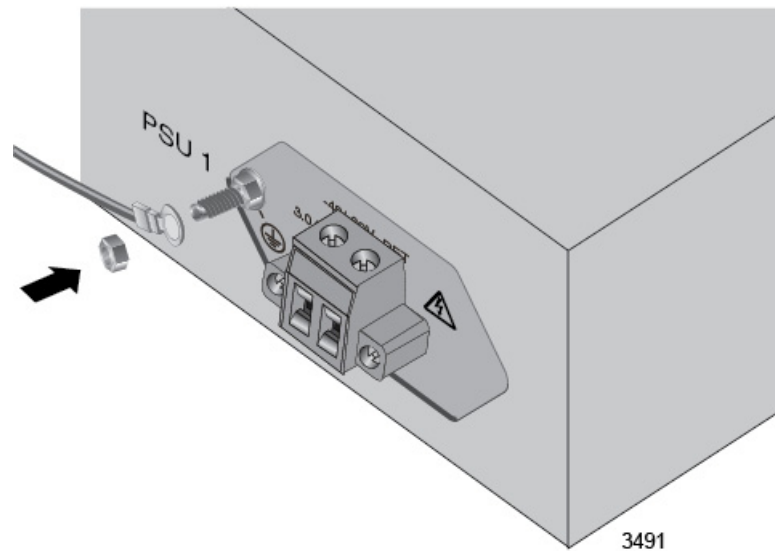

Figure 37. Installing the Grounding Wire

5. Connect the other end of the grounding wire to the building protective earth.
6. After installing the grounding wire, go to “Connecting the -48/-60VDC and RETURN Wires”.

Connecting the -48/-60VDC and RETURN Wires

After installing the grounding wire, connect the -48/-60VDC and RETURN wires by performing the following procedure:



Warning

As a safety precaution, install a circuit breaker with a minimum value of 10 Amps between the equipment and the DC power source.

Always connect the wires to the LAN equipment first before connecting the wires to the circuit breaker. Do not work with HOT leads to avoid the danger of physical injury from electrical shock. Always be sure that the circuit breaker is in the OFF position before connecting the wires to the breaker. ⚡ E9



Warning

The power input must be provided by a SELV source only, per IEC60950. Do not connect to a centralized DC battery bank. ⚡ E31

1. Verify that the DC circuit is powered off.
2. Use a 3mm flat-head screwdriver to loosen the two captive screws that secure the DC connector to the chassis. Refer to Figure 38 on page 85.

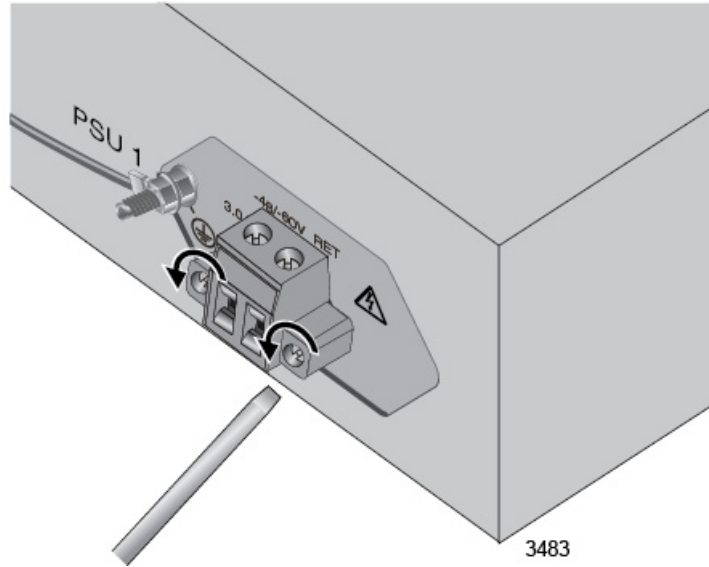

Figure 38. Loosening the Two Captive Screws on the DC Connector

3. Slide the DC connector from the chassis. Refer to Figure 39.

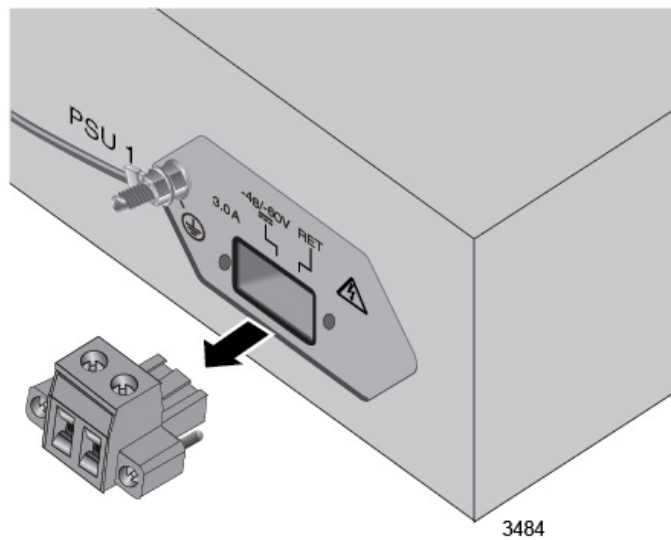

Figure 39. Removing the DC Connector

4. Use a 3mm (0.125 in.) flat-head screwdriver to loosen the two captive screws on the top of the DC connector. Refer to Figure 40 on page 86.

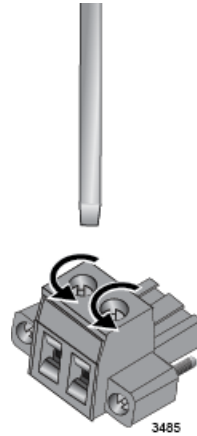

Figure 40. Loosening the Captive Screws on the DC Connector

5. Remove 6.5mm (0.25 in.) of insulation from one end of the black RETURN wire. Refer to Figure 41.

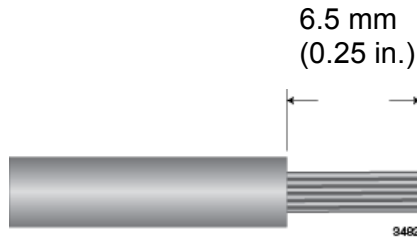

Figure 41. Stripping a Stranded Power Wire

6. Insert the black RETURN wire into the right connector and secure it by tightening the captive screw with a flat-head screwdriver. Allied Telesis recommends tightening the screw to 5 in-lbs. Refer to Figure 42.

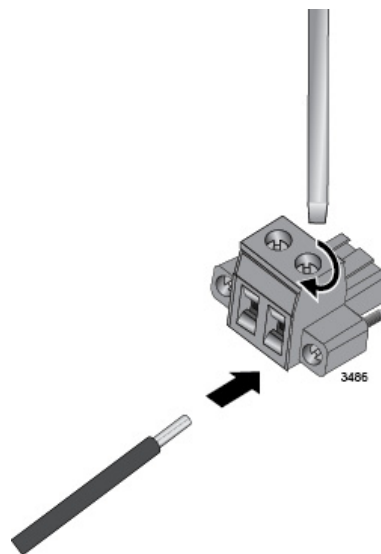

Figure 42. Inserting the RETURN Wire

7. Remove 6.5mm (0.25 in.) of insulation from one end of the red -48/-60VDC wire. Refer to Figure 41 on page 86.
8. Insert the red -48/-60VDC wire into the left connector and secure it by tightening the captive screw with a flat-head screwdriver. Allied Telesis recommends tightening the screw to 5 in-lbs. Refer to Figure 43.

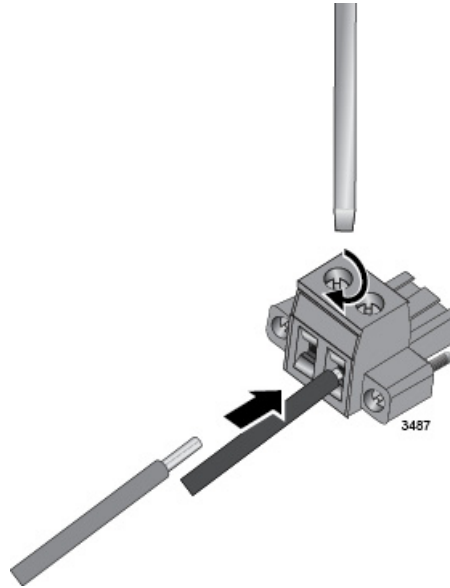

Figure 43. Inserting the -48/-60VDC Wire

9. Slide the DC connector into the slot on the switch. Refer to Figure 44.

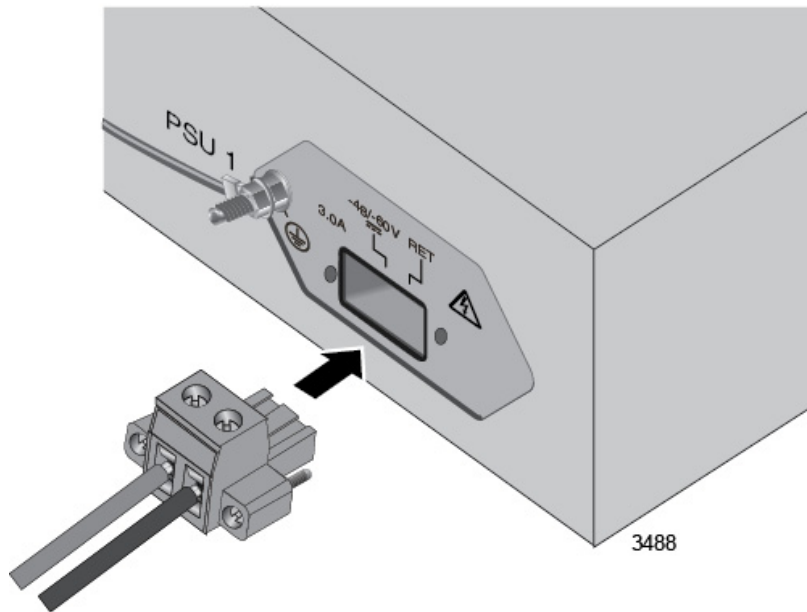

Figure 44. Sliding the DC Connector into the Switch

10. Tighten the two captive screws on the sides of the DC connector to secure the connector to the switch. Refer to Figure 45.

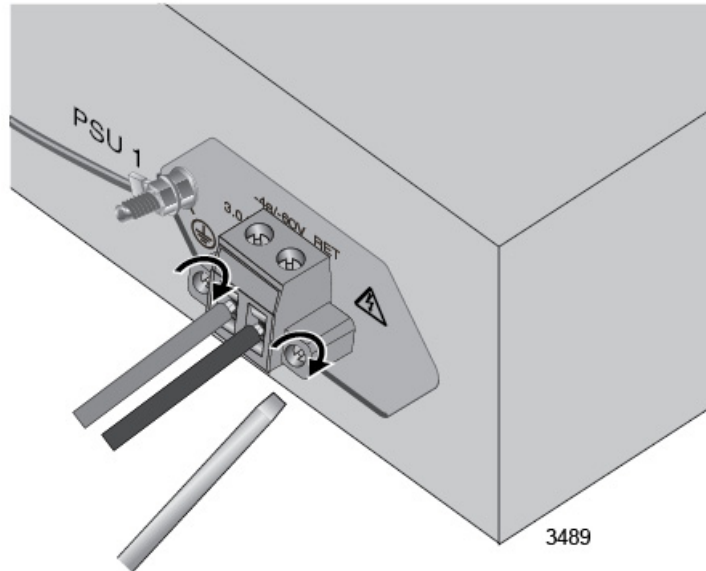

Figure 45. Securing the DC Connector to the Switch

1. Verify that the DC circuit is powered off.
2. Connect the -48/-60VDC and RETURN wires to the DC circuit.
3. Repeat this procedure to connect the power wires to the second DC power supply in the switch.
4. Power on the DC circuits.



Warning

Circuit breaker is used as a disconnection device. To de-energize the equipment, shut down the circuit breaker and then disconnect the input wire. ⚡ E38

5. Do one of the following:
 - ❑ To monitor the switch as it initializes the management software, which takes about thirty seconds, go to “Monitoring the Initialization Processes” on page 89.
 - ❑ If you do not want to monitor the initialization process, wait thirty seconds for the switch to initialize its management software and then go to “Configuring the Switch for Stand-alone Operations” on page 93.

Monitoring the Initialization Processes

It takes about thirty seconds for the switch to initialize its management software programs and features, and load the default configuration. You may monitor the progress of the initialization process by watching the switch ID LED. It displays the number “8” for about the first 15 seconds and then the number “1.”

You may also monitor the bootup sequence by connecting a terminal or computer that has a terminal emulator program, to the Console port on the master switch. You will see the messages in Figure 46 on page 90 to Figure 48 on page 92.

```
Bootloader 2.0.11 loaded
Press <Ctrl+B> for the Boot Menu

Reading filesystem...
Loading flash:x510-5.4.2a-20120727-1.rel...
Verifying release... OK
Booting...
Starting base/first... [ OK ]
Mounting virtual filesystems... [ OK ]

      _____
     /  \  /  \  /  \
    /    \ /    \ /    \
   /      \ /      \ /      \
  /        \ /        \ /        \
 /          \ /          \ /          \
/            \ /            \ /            \
 \            / \            / \            /
  \          / \          / \          /
   \        / \        / \        /
    \      / \      / \      /
     \    / \    / \    /
      \  / \  /  \  /  \
       \ / \ /  \ /  \
        \_/_\_/  \_/_\_/

Allied Telesis Inc.
AlliedWare Plus (TM) v5.4.2A
Current release filename: x510-5.4.2a-20120727-1.rel
Original release filename: x510-5.4.2A-20120727-1.rel
Built: Fri Jul 27 04:11:42 NZST 2012 by: maker@maker04-build
Mounting static filesystems... [ OK ]
Checking flash filesystem... [ OK ]
Mounting flash filesystem... [ OK ]
Checking NVS filesystem... [ OK ]
Mounting NVS filesystem... [ OK ]
Starting base/dbus... [ OK ]
Starting base/syslog... [ OK ]
```

Figure 46. Switch Initialization Messages

```

Starting base/loopback... [ OK ]
Starting base/poe_done... [ OK ]
Starting base/sysctl... [ OK ]
Received event poefw.done
Starting base/portmapper... [ OK ]
Received event syslog.done
Starting base/reboot-stability... [ OK ]
Starting base/autofs-card... [ OK ]
Checking system reboot stability... [ OK ]
Starting base/cron... [ OK ]
Starting base/appmond... [ OK ]
Starting hardware/openhpi... [ OK ]
Starting hardware/timeout... [ OK ]
Starting base/inet... [ OK ]
Starting base/modules... [ OK ]
Received event modules.done
Received event board.inserted
Received event hardware.done
Starting network/startup... [ OK ]
Starting network/stackd... [ OK ]
Starting network/election.timeout... [ OK ]
Received event network.enabled

Initializing HA processes:
openhpid, hostd, cntrd, nsm, auth, epsr, hsl
imiproxyd, irdpd, lldpd, loopprot, mstp, ospf6d, ripd
ripngd, rmon, sflowd, udldd, vrrpd, bgpd, imi
lACP, ospfd, pdmd, pimd

Received event network.initialized
03:44:11 awplus-1 VCS[826]: No neighboring members found, unit may be in a
stand alone configuration
03:44:11 awplus-1 VCS[826]: Startup speed can be improved by adding 'no stack
1
enable' to configuration
Received event vcs.elected-master
03:44:11 awplus-1 VCS[826]: Member 1 (0015.774f.ed30) has become the Active
Master

```

Figure 47. Switch Initialization Messages (Continued)

```
Assigning Active workload to HA processes:
hsl, nsm, rmond, sflowd, vrrpd, irddpd, lacpd
lldpd, loopprotd, mstpd, authd, epsrd, imi, imiproxyd

Received event network.activated

Loading default configuration
warning: flash:/default.cfg does not exist, loading factory defaults.
..
done!
Received event network.configured

awplus login:
```

Figure 48. Switch Initialization Messages (Continued)

After the switch has initialized its management software, go to “Configuring the Switch for Stand-alone Operations” on page 93 to confirm its ID number.

Configuring the Switch for Stand-alone Operations

After the switch has initialized its management software, examine the switch ID LED on the front panel and do one of the following:

- ❑ If the LED is displaying “0,” the installation procedure is complete. The switch is now ready for network operations as a stand-alone unit. Refer to the *Software Reference for x510 Series Switches, AlliedWare Plus Operating System*, for instructions on how to configure the operating parameters.
- ❑ If the LED is displaying a number other than “0,” perform the following procedures to disable the VCStack feature.

You can disable the VCStack feature from a local management session of the switch using the Console port. To start a local management session, go to “Starting a Local Management Session”.



Caution

You have to reset the switch to disable the VCStack feature. Some network traffic may be lost if the device is already connected to a live network. *See* E89

Note

The initial management session of the switch must be from the Console port.

Starting a Local Management Session

This procedure requires a terminal or a terminal emulator program and the management cable that comes with the switch. To start a local management session on the switch, perform the following procedure:

1. Connect the RJ-45 connector on the management cable to the Console port on the front panel of the switch, as shown in Figure 49 on page 94.

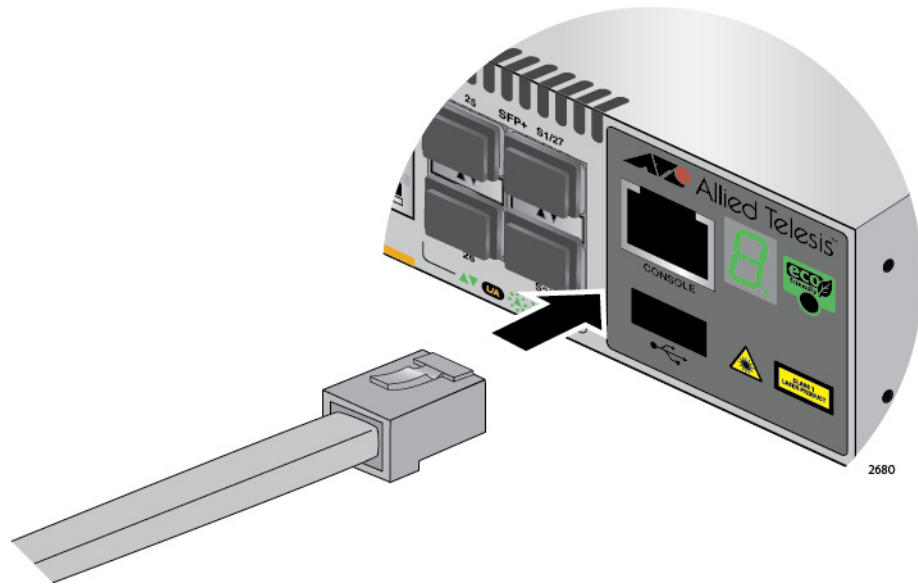

Figure 49. Connecting the Management Cable to the Console Port

2. Connect the other end of the cable to an RS-232 port on a terminal or PC with a terminal emulator program.
3. Configure the terminal or terminal emulator program as follows:
 - Baud rate: 9600 bps (The baud rate of the Console Port is adjustable from 1200 to 115200 bps. The default is 9600 bps.)
 - Data bits: 8
 - Parity: None
 - Stop bits: 1
 - Flow control: None

Note

The port settings are for a DEC VT100 or ANSI terminal, or an equivalent terminal emulator program.

4. Press Enter.
You are prompted for a user name and password.
5. When prompted for a user name, go to “Disabling VCStack” on page 95.

Disabling VCStack

To disable the VCStack feature to use the switch as stand-alone unit, perform the following procedure:



Caution

You have to reset the switch to disable the VCStack feature. Some network traffic may be lost if the device is already connected to a live network. [E89](#)

1. When prompted, enter a user name and password to log on the switch. If this is the initial management session of the switch, enter “manager” as the user name and “friend” as the password. The user name and password are case sensitive.

The local management session starts when the User Exec mode prompt, shown in Figure 50, is displayed.

```
awplus>
```

Figure 50. User Exec Mode Prompt

Note

The User Exec mode is the first level in the command mode interface. For complete information on the modes and commands, refer to the *Software Reference for x510 Series Switches, AlliedWare Plus Operating System* from www.alliedtelesis.com/support.

2. Enter the SHOW STACK command to display the status of the VCStack feature. Figure 51 is an example of the command.

```
awplus> show stack
Virtual Chassis Stacking summary information
ID      Pending ID  MAC address      Priority  Status  Role
1       -            0015:774f:ed30  128     Ready   Active Master
Operational Status
Stack MAC address 0015:774f:ed30
awplus(config)#
```

Figure 51. SHOW STACK Command

3. Review the following items:
 - If the Operational Status is “Stacking Hardware Disabled,” the VCStack feature is already disabled on the switch and the SFP+ stacking slots may be used with regular SFP or SFP+ transceivers.

- If the Operational Status is “Standalone Unit,” as shown in Figure 51 on page 95, the VCStack feature is active on the unit. You must disable it by performing the steps in the rest of this procedure before you can use the SFP+ stacking slots with regular SFP or SFP+ transceivers. The reason the status says “standalone” is because the switch considers itself a stack of one switch.
- 4. Move to the Global Configuration mode by entering the ENABLE and CONFIGURE TERMINAL commands, as shown in Figure 52.

```
awplus> enable
awplus# configure terminal
Enter configuration commands, one per line. End with CNTL/Z
awplus(config)#
```

Figure 52. Moving to the Global Configuration Mode

- 5. To disable the VCStack feature on the switch, enter the NO STACK ENABLE command, which has this format:

```
no stack id enable
```

The ID parameter is the ID number of the switch, displayed on the ID LED. Replace the parameter with whatever number is on the ID LED. For example, if the ID number of the switch is 1, the default value, enter the command as follows:

```
awplus(config)# no stack 1 enable
```

This confirmation prompt in Figure 53 is displayed.

```
Warning; This will disable the stacking hardware on member-1.
Are you sure you want to continue? (y/n):
```

Figure 53. Confirmation Prompt for the NO STACK ENABLE Command

- 6. Type Y to disable VCStack on the switch or N to cancel the procedure.
- 7. Enter the EXIT command to return to the Privileged Exec mode, as shown in Figure 54.

```
awplus(config)# exit
awplus#
```

Figure 54. Returning to the Privileged Exec Mode

- 8. Enter the WRITE command to save your change in the configuration file. The switch displays the confirmation prompt in Figure 55 on page 97.

```
awplus# write
Building configuration ...
[OK]
awplus#
```

Figure 55. Saving the Changes with the WRITE Command

9. Enter the REBOOT command to reboot the switch.
10. At the confirmation prompt, type “Y” for yes.
11. Wait for the switch to initialize its management software and afterwards examine the Switch ID LED. The switch is ready for normal network operations as a stand-alone unit when its ID number is “0.” Refer to the *Software Reference for x510 Series Switches, AlliedWare Plus Operating System*, for instructions on how to configure the operating parameters. If the number is not “0,” repeat this procedure.

Confirming the Status of the VCStack Feature

Another way to confirm that VCStack is disabled on the switch is by displaying the status of the last two SFP+ slots on the switch. These are slots 27 and 28 on the 28-port switches and slots 51 and 52 on the 52-port switches. If VCStack is disabled, you should be able to display the status of the slots even when they do not have transceivers. If VCStack is not disabled, the switch displays a message that it cannot find the slots. To view the status of the stacking slots, perform this procedure:

1. Start a management session on the switch. For directions, refer to “Configuring the Switch for Stand-alone Operations” on page 93.
2. Log on to the switch. The default user name is “manager” and the password is “friend”.
3. From either the User Exec mode or Privileged Exec mode, enter the SHOW INTERFACE command to display the status of one of the last two SFP+ slots on the switch. For example, for the AT-x510-28GTX Switch, enter this command to view the status of slot 27:

```
show interface port1.0.27
```

4. For the AT-x510-52GTX Switch, enter this command to view the status of slot 51:

```
show interface port1.0.51
```

If VCStack is disabled, the switch displays the status of the designated slot. An example is shown in Figure 56 on page 98.

```
awplus>show interface port1.0.51
Interface port1.0.51
  Scope: both
  Link is DOWN, administrative state is UP
  Thrash-limiting
    Status Not Detected, Action learn-disable, Timeout 1(s)
  Hardware is Ethernet, address is 0015.774f.ed30
  index 5051 metric 1 mru 1500
  configured duplex auto, configured speed auto, configured polarity auto
  <UP,BROADCAST,MULTICAST>
  SNMP link-status traps: Disabled
    input packets 0, bytes 0, dropped 0, multicast packets 0
    output packets 0, bytes 0, multicast packets 0 broadcast packets 0
  Time since last state change: 0 days 00:42:49
```

Figure 56. Status of a Stacking Slot When VCStack is Disabled

The switch displays the message in Figure 57 if VCStack is not disabled, in which case you need to disable it by performing the commands in “Disabling VCStack” on page 95.

```
awplus# show interface port1.0.51
%Can't find interface port1.0.51
awplus#
```

Figure 57. Status of a Stacking Slot When VCStack is Enabled

Specifying Ports in the Command Line Interface for Stand-alone Switches

The command line interface in the management software on the switch has a parameter that you use to specify the individual ports. The parameter is the PORT parameter and Figure 58 shows its format.

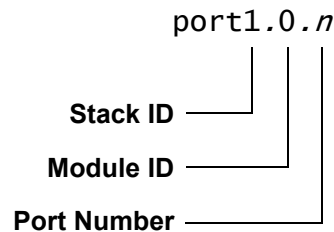

Figure 58. PORT Parameter in the Command Line Interface

The first number is the switch's ID number. The ID number for stand-alone switches is not the value 0 displayed on the Switch ID LEDs. Rather, it is 1. Be sure to enter 1, not 0, as the ID number in the PORT parameter when configuring ports on stand-alone switches.

The module ID value is used with multi-module products. This value does not apply to the x510 Series switches and should always be 0.

The third value is a port number on the switch. You may specify only one port number in a PORT parameter, but you may specify more than one PORT parameter in many commands where the parameter is supported.

Here is an example of the PORT parameter on a stand-alone switch. It uses the INTERFACE command to enter the Port Interface mode for ports 15 and 17:

```
awplus> enable
awplus# configure terminal
awplus(config)# interface port1.0.15,port1.0.17
```

For instructions on the command line interface and the PORT parameter, refer to the *Software Reference for x510 Series Switches, AlliedWare Plus Operating System*.

Chapter 6

Troubleshooting

This chapter contains suggestions on how to troubleshoot the switch if a problem occurs.

Note

For further assistance, please contact Allied Telesis Technical Support at www.alliedtelesis.com/support.

Problem 1: The Switch ID LED on the front of the switch is off.

Solutions: The unit is not receiving power. Try the following:

- Verify that the power cord is securely connected to the power source and to the AC connector on the back panel of the switch.
- Verify that the power outlet has power by connecting another device to it.
- Try connecting the unit to another power source.
- Try a different power cord.
- Verify that the voltage from the power source is within the required levels for your region.

Problem 2: All of the port LEDs are off even though the ports are connected to active network devices.

Solution: The switch may be operating in the low power mode. To toggle on the LEDs, press the eco-friendly button on the front panel of the switch. You may also toggle the LEDs off and on with the ECOFRIENDLY LED and NO ECOFRIENDLY LED commands in the command line interface.

Problem 3: A twisted pair port on the switch is connected to a network device, but the port's LINK/ACT LED is off.

Solutions: The port is unable to establish a link to a network device. Try the following:

- Verify that the port is connected to the correct twisted pair cable. This is to eliminate the possibility that the port is connected to the wrong network device.
- Verify that the network device connected to the twisted pair port is powered on and is operating properly.

- ❑ Try connecting another network device to the twisted pair port with a different cable. If the twisted pair port is able to establish a link, then the problem is with the cable or the other network device.
- ❑ Verify that the twisted pair cable does not exceed 100 meters (328 feet).
- ❑ Verify that you are using the appropriate category of twisted pair cable. The cable types are listed in Table 1 on page 28 for the 10/100/1000Base-T ports.

Note

A 1000Base connection may require five to ten seconds to establish a link.

Problem 4: The LINK/ACT LED for an SFP or SFP+ transceiver is off.

Solutions: The fiber optic port on the transceiver is unable to establish a link to a network device. Try the following:

- ❑ Verify that the remote network device connected to the fiber optic port is operating properly.
- ❑ Verify that the fiber optic cable is securely connected to the port on the SFP or SFP+ module and to the port on the remote network device.
- ❑ Check that the transceiver is fully inserted in the slot.
- ❑ If you are using SFP+ slots 27 or 28 on the 28-port switches or slots 51 and 52 on the 52-port switches, check that VCStack is disabled on the switch. The VCStack feature has to be disabled before you can use these slots for regular SFP or SFP+ transceivers. For instructions, refer to “Configuring the Switch for Stand-alone Operations” on page 93
- ❑ Verify that the operating specifications of the fiber optic ports on the transceiver and remote network device are compatible.
- ❑ Verify that the correct type of fiber optic cabling is being used.
- ❑ Verify that the port is connected to the correct fiber optic cable. This is to eliminate the possibility that the port is connected to the wrong remote network device.
- ❑ Try connecting another network device to the fiber optic port using a different cable. If the port is able to establish a link, then the problem is with the cable or with the other network device.
- ❑ Use the switch’s management software to verify that the port is enabled.
- ❑ If the remote network device is a managed device, use its management firmware to determine whether its port is enabled.

- ❑ Test the attenuation of both directions on the fiber optic cable with a fiber optic tester to determine whether the optical signal is too weak (sensitivity) or too strong (maximum input power).

Problem 5: Network performance between a twisted pair port on the switch and a network device is slow.

Solution: There might be a duplex mode mismatch between the port and the network device. This can occur when a twisted pair port using Auto-Negotiation is connected to a remote device that has a fixed speed of 10 or 100 Mbps and a fixed duplex mode of full duplex. If this is the cause of the problem, adjust the duplex mode of the port on the network device or switch so that both ports are using the same duplex mode. You can use either the LEDs or management software on the switch to determine the duplex mode settings of the ports. The LEDs are described in Table 6 on page 38.

Problem 6: The switch functions intermittently.

Solutions: Check the system hardware status through the management software:

- ❑ Use the SHOW SYSTEM ENVIRONMENT command in the Privileged Exec mode to verify that the input voltage from the power source to the switch is stable and within the approved operating range. The unit will shut down if the input voltage fluctuates above or below the approved operating range.
- ❑ Use the SHOW SYSTEM ENVIRONMENT command in the Privileged Exec mode to verify that the fan is operating correctly.
- ❑ Verify that the location of the switch allows for adequate airflow. The unit will shut down if it is in danger of overheating.

Problem 7: The Switch ID LED on the front of the switch is flashing the letter “F.”

Solutions: One or more of the following problems has occurred:

- ❑ A cooling fan has failed.
- ❑ The input voltage on one or both of the power supplies is outside the normal operating range.
- ❑ The internal temperature of the switch has exceeded the normal operating range and the switch may shut down.

Contact your Allied Telesis sales representative for assistance.

Problem 8: The AT-x510-28GPX, AT-x510L-28GP, AT-x510-52GPX, or AT-x510L-52GP Switch is not providing power to a PoE device.

Solutions: Try the following:

- ❑ Review the PD's documentation to confirm that the device supports Mode A of the IEEE 802.3at standard. Mode A is one of two modes that define the connector pins that deliver the power from the port on the line card to the PD. In Mode A, the power is carried on pins 1, 2, 3, and 6 on the RJ-45 port, the same pins that carry the network traffic. The second mode, Mode B, defines pins 4, 5, 7, and 8 as the power carriers. The AT-x510-28GPX, AT-x510L-28GP, AT-x510-52GPX, and AT-x510L-52GP Switches do not support Mode B. Most powered devices are designed to accept power by either mode, but some legacy devices may only support one mode. This can be verified by reviewing the device's documentation or data sheet. Legacy devices that only support Mode B will not work with the switches.
- ❑ Check that the device's power requirements do not exceed 30 W. This can be verified by reviewing the device's documentation or data sheet.
- ❑ Verify that you are using the appropriate category of twisted-pair cable by referring to Table 3 on page 30.
- ❑ Use the management software on the switch to determine whether PoE is enabled on the port. The default setting for PoE is enabled.
- ❑ Use the management software on the switch to determine whether the PoE power setting for the port has been reduced to a value below the power requirements of the device.
- ❑ Try connecting the device to a different port on the switch.

Appendix A

Technical Specifications

This appendix contains the following sections:

- “Physical Specifications”
- “Environmental Specifications” on page 107
- “Power Specifications” on page 107
- “Certifications” on page 109
- “RJ-45 Twisted Pair Port Pinouts” on page 109
- “RJ-45 Style Serial Console Port Pinouts” on page 111

Physical Specifications

Dimensions (H x W x D)

Table 11. Product Dimensions

AT-x510-28GTX (AC model)	4.4 cm x 44.0 cm x 32.3 cm (1.7 in. x 17.3 in. x 12.7 in.)
AT-x510-28GPX (AC model)	4.4 cm x 44.0 cm x 39.8 cm (1.7 in. x 17.3 in. x 15.7 in.)
AT-x510-28GSX (AC model)	4.4 cm x 44.0 cm x 32.3 cm (1.7 in. x 17.3 in. x 12.7 in.)
AT-x510-28GSX-80 (DC model)	4.4 cm x 44.0 cm x 32.3 cm (1.7 in. x 17.3 in. x 12.7 in.)
AT-x510L-28GT (AC model)	4.4 cm x 44.0 cm x 29.1 cm (1.7 in. x 17.3 in. x 11.5 in.)
AT-x510L-28GP (AC model)	4.4 cm x 44.0 cm x 32.3 cm (1.7 in. x 17.3 in. x 12.7 in.)
AT-x510-52GTX (AC model)	4.4 cm x 44.0 cm x 32.3 cm (1.7 in. x 17.3 in. x 12.7 in.)
AT-x510-52GPX (AC model)	4.4 cm x 44.0 cm x 40.0 cm (1.7 in. x 17.3 in. x 15.7 in.)

Table 11. Product Dimensions (Continued)

AT-x510L-52GT (AC model)	4.4 cm x 44.0 cm x 29.1 cm (1.7 in. x 17.3 in. x 11.5 in.)
AT-x510L-52GP (AC model)	4.4 cm x 44.0 cm x 32.3 cm (1.7 in. x 17.3 in. x 12.7 in.)

Weights

Table 12. Product Weights

AT-x510-28GTX (AC model)	4.3 kg (9.5 lb.)
AT-x510-28GPX (AC model)	5.8 kg (12.8 lb.)
AT-x510-28GSX (AC model)	4.8 kg (10.6 lb.)
AT-x510-28GSX-80 (DC model)	4.8 kg (10.6 lb.)
AT-x510L-28GT (AC model)	4.2 kg (9.3 lb.)
AT-x510L-28GP (AC model)	5.2 kg (11.5 lb.)
AT-x510-52GTX (AC model)	5.2 kg (11.5 lb.)
AT-x510-52GPX (AC model)	6.2 kg (13.7 lb.)
AT-x510L-52GT (AC model)	4.8 kg (10.6 lb.)
AT-x510L-52GP (AC model)	5.7 kg (12.6 lb.)

Ventilation

Table 13. Ventilation Requirements

Recommended Minimum Ventilation on All Sides	10 cm (4.0 in)
--	----------------

Environmental Specifications

Table 14. Environmental Specifications

Operating Temperature	0° C to 45° C (32° F to 113° F)
Storage Temperature	-25° C to 70° C (-13° F to 158° F)
Operating Humidity	5% to 90% noncondensing
Storage Humidity	5% to 95% noncondensing
Maximum Operating Altitude	3,000 m (9,842 ft)
Maximum Nonoperating Altitude	4,000 m (13,100 ft)

Power Specifications

Maximum Power Consumption

Table 15. Maximum Power Consumption

AT-x510-28GTX (AC model)	40 watts per input
AT-x510-28GPX (AC model)	210 watts per input
AT-x510-28GSX (AC model)	40 watts per input
AT-x510-28GSX-80 (DC model)	40 watts per input
AT-x510L-28GT (AC model)	52 watts per input
AT-x510L-28GP (AC model)	290 watts per input
AT-x510-52GTX (AC model)	70 watts per input
AT-x510-52GPX (AC model)	270 watts per input
AT-x510L-52GT (AC model)	86 watts per input
AT-x510L-52GP (AC model)	320 watts per input

Input Voltages

Table 16. Input Voltages

AT-x510-28GTX (AC model)	100-240 VAC, 1.0A maximum, 50/60 Hz per input
AT-x510-28GPX (AC model)	100-240 VAC, 3.0A maximum, 50/60 Hz per input
AT-x510-28GSX (AC model)	100-240 VAC, 1.0A maximum, 50/60 Hz per input
AT-x510-28GSX-80 (DC model)	-48/-60V, 3.0A maximum
AT-x510L-28GT (AC model)	100-240 VAC, 1.0A maximum, 50/60 Hz per input
AT-x510L-28GP (AC model)	100-240 VAC, 3.0A maximum, 50/60 Hz per input
AT-x510-52GTX (AC model)	100-240 VAC, 1.0A maximum, 50/60 Hz per input
AT-x510-52GPX (AC model)	100-240 VAC, 3.0A maximum, 50/60 Hz per input
AT-x510L-52GT (AC model)	100-240 VAC, 1.0A maximum, 50/60 Hz per input
AT-x510L-52GP (AC model)	100-240 VAC, 3.0A maximum, 50/60 Hz per input

Certifications

Table 17. Product Certifications

EMI (Emissions)	FCC Class A, EN55022 Class A, EN61000-3-2, EN61000-3-3, VCCI Class A, CISPR Class A, C-TICK, CE
EMC (Immunity)	EN55024
Electrical and Laser Safety	EN60950-1 (TUV), UL 60950-1 (cULUS), EN60825
Compliance Marks	CE, cULUS, TUV, C-Tick

RJ-45 Twisted Pair Port Pinouts

Figure 59 illustrates the pin layout of the RJ-45 connectors and ports.

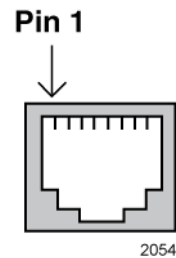

Figure 59. RJ-45 Socket Pin Layout (Front View)

Table 18 lists the pin signals for 10 and 100 Mbps.

Table 18. Pin Signals for 10 and 100 Mbps

Pin	MDI Signal	MDI-X Signal
1	TX+	RX+
2	TX-	RX-
3	RX+	TX+
4	Not used	Not used
5	Not used	Not used
6	RX-	TX-
7	Not used	Not used
8	Not used	Not used

Table 19 lists the pin signals when a port operating at 1000 Mbps.

Table 19. Pin Signals for 1000 Mbps

Pinout	Pair
1	Pair 1 +
2	Pair 1 -
3	Pair 2 +
4	Pair 3 +
5	Pair 3 -
6	Pair 2 -
7	Pair 4 +
8	Pair 4 -

RJ-45 Style Serial Console Port Pinouts

Table 20 lists the pin signals of the RJ-45 style serial Console port.

Table 20. RJ-45 Style Serial Console Port Pin Signals

Pin	Signal
1	Looped to pin 8
2	Looped to pin 7
3	Transmit Data
4	Ground
5	Ground
6	Receive Data
7	Looped to pin 2
8	Looped to pin 1

