

WG209– USB WiFi Module Datasheet

Name: 802.11b/g/n USB WiFi Module

Model NO.: WG209

Revision: V2.01

Revision History:

Revision	Description	Approved	Date
V1.01	Initial	George	20140115
V2.01	FCC/CE certification	George	20140712

General Description

WG209 is a 802.11n/ b/g WiFi one-stream USB interface designed specifically to provide enhanced WiFi performance and value for home gateways, set-top boxes, gaming consoles, printers, IP cameras, and variety of other products that host processors not originally intended to support WiFi functions. WG209's MT7601 single-chip features a new architecture that integrates both a CPU and memory to run more of the WiFi function on-chip. The integrated CPU offloads the wireless processing overhead from the host appliance and enables consumer electronic devices to support WiFi functions seamlessly without change of original host processors.

Applications

- Desktop Computer
- Laptop Computer,
- IP Camera
- IP TV
- IP DVD(Internet VOD Player)
- Set Top Box
- Home Gateways
- Gaming Consoles
- Printers



Figure 1: WG209 Top View

Features

- Compliant to IEEE 802.11b/g/n WLANs
- 2.4 GHz WLAN MAC/BB processing
- Security: WEP 64/128, WPA, WPA2, TKIP, AES, WAPI
- Supports for Windows XP 32/64, 2000, Vista 32/64bit, Windows 7 32/64bit, Linux, Android.
- Power Supply: 3.3V or 5.0V
- Package: SMD or 4pin/6pin Connector
- USB 2.0 high speed interface.
- Supports 72.2 Mbps for 20 MHz and 150 Mbps for 40 MHz channel operations.
- FCC、CE certification.
- RoHS compliance meets environment-friendly requirement.
- 30(L) x 15(W) x 2.8(H) mm small dimension

Applications Block Diagram

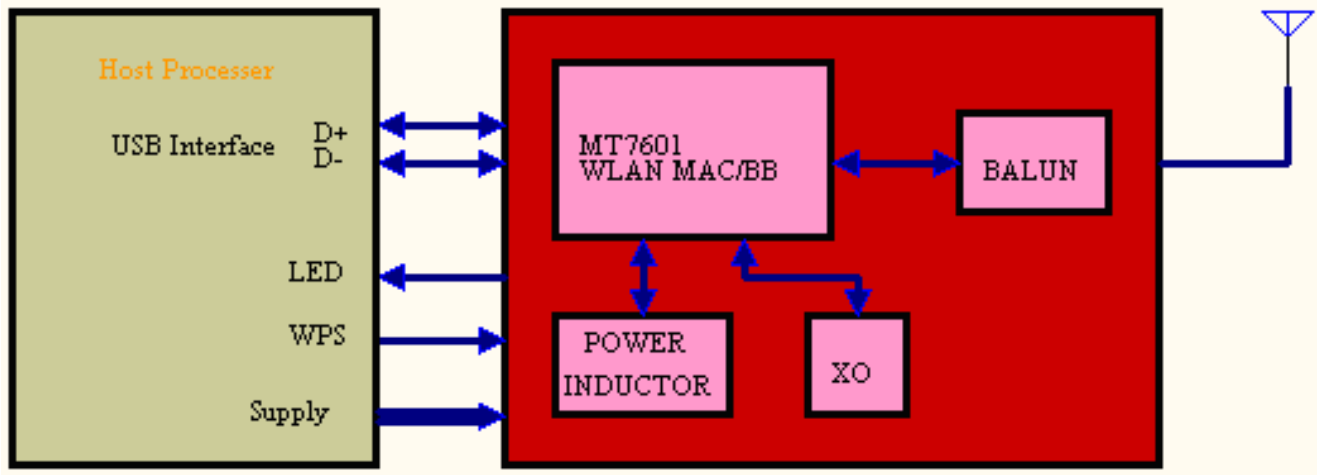

Figure 2: WG209 Block Diagram

Ordering Information

WG209_XXX		
	Package:	S-SMD 6-6pin conenctor 4-4pin conenctor
	Antenna Type:	E-IPEX conenctor P-PCB antenna
	Power Supply:	3-3.3V 5-5.0V

Performance Specification

Wireless Specifications

Model	WG209
Antenna Type	IPEX connector or PCB Antenna
Standard Conformance	802.11b, 802.11g, and 802.11n
Frequency Range	USA: 2.400 ~ 2.483GHz
	Europe: 2.400 ~ 2.483GHz
	Japan: 2.400 ~ 2.497GHz
	China: 2.400 ~ 2.483GHz
Modulation Technique	DSSS with CCK, DQPSK, DBPSK
	OFDM with BPSK, QPSK, 16QAM, 64QAM
Channel Spacing	5MHz/20MHz/40MHz
Data Rate	802.11b: 1, 2, 5.5 and 11Mbps
	802.11g: 6, 9, 12, 18, 24, 36, 48, 54Mbps
	802.11n: 20MHz channel: 1Nss: 65Mbps @ 800GI, 72.2Mbps @ 400GI (Max.)
	40MHz channel: 1Nss: 135Mbps @ 800GI, 150Mbps @ 400GI (Max.)
Operating Channels	USA/Canada: 11 (1~11)
	Major Europe Countries: 13 (1~13)
	France: 4 (10~13)
	Japan: 14 for 802.11b (1~13 or 14th), 13 for 802.11g (1~13)
	China: 13 (1~13)
Wi-Fi Compliance	Wi-Fi 2.4GHz by request
Certification	FCC、CE
Security	64/128/152-bit WEP encryption
	WPA/WPA2 encryption
	AES-CCM & TKIP encryption

Transmit Power And Receive Sensitivity

Transmit Power	target power tolerance ± 2 dBm
-----------------------	------------------------------------

	802.11b:	+18 dBm for 802.11b CCK		
	802.11g:	+15dBm @ 6, 9, 12,18,24,36,48Mbps		
		+15dBm @ 54Mbps		
	802.11n HT20:	+13dBm @ MCS 7/15		
	802.11n HT40:	+13dBm @ MCS 7/15		
Receiver Sensitivity		Data Rate	IEEE Spec(1 Rx dBm)	Typical
	802.11b	1M	-82	-92
		5.5M	-80	-89
		11M	-76	-87
	802.11g	6M	-82	-92
		9M	-81	-92
		12M	-79	-91
		18M	-77	-90
		24M	-74	-86
		36M	-70	-83
		48M	-66	-78
		54M	-65	-76
		802.11n HT20	MCS0	-82
	MCS1		-79	-91
	MCS2		-77	-90
	MCS3		-74	-85
	MCS4		-70	-82
	MCS5		-66	-79
	MCS6		-65	-75
	MCS7		-64	-73
	802.11n HT40	MCS0	-79	-88
		MCS1	-76	-87
		MCS2	-74	-86
		MCS3	-71	-82
		MCS4	-67	-78
		MCS5	-63	-75
		MCS6	-62	-72
		MCS7	-61	-70
Operation Distance		Outdoor		Indoor
	802.11b	150m @ 11Mbps		30m @ 11Mbps
		300m @ 1Mbps		100m @ 1Mbps

	802.11g	50m @ 54Mbps	30m @ 54Mbps
		300m @ 6Mbps	100m @ 6Mbps
	802.11n HT20	30m @ 150Mbps	20m @ 150Mbps
		30m @ 65Mbps	20m @ 65Mbps
		250m @ 6.5Mbps	100m @ 6.5Mbps

Electrical Characteristics

Absolute Maximum Rating

Parameter	Symbol	Min	Max	Units
Supply Voltage	VCC_3V3	0.3	4	V
Supply Voltage	VCC_5.0V	0.3	7	V
RF input (reference to 50 Ω)	RFin		10	dBm
Storage Temperature	Tstore	-40	125	℃
Junction Temperature	Tjunction		125	℃
Electrostatic Discharge Tolerance	ESD		2000	V

Operating Conditions

Parameter	Symbol	Min	Typ	Max	Units
Supply Voltage	VCC_3V3	3	3.3	3.6	V
Supply Voltage	VCC_5.0V	3.6	5.0	7.0	V
RF input (reference to 50 Ω)	RFin		10	dBm	dBm
Case temperature	Tcase	-10	45	110	℃
Thermal Parameter	PsiJT			3.23	℃/W

Power Consumption for 2.4 GHz Operation

Mode	Operating Mode	VDD_3V3(mA)
HT40 @ 15dBm	Sleep	50

	TX	210
	RX	151
802.11g @17dBm	Sleep	50
	TX	233
	RX	151
802.11b @19dBm	Sleep	50
	TX	242
	RX	151

Note: For Tx, transmitter and synthesizer are on. Tx power at 18 dBm for 802.11b/g/HT20 and 16 dBm HT40. For Rx, receiver and synthesizer are on with maximum receiver gain.

Module Pinout

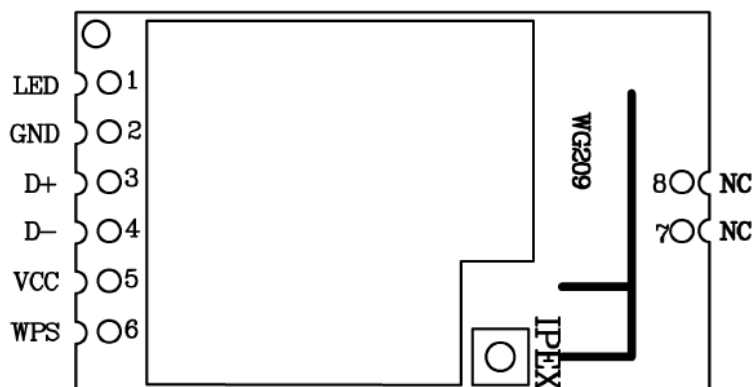

Figure 3: WG209 Pin Name

Pin Description

Pin No.	Pin name	I/O	Description	Remark
1	LED	O	LED pin	
2	GND	G	Ground	
3	D+	I/O	USB Interface DP	
4	D-	I/O	USB Interface DM	
5	VCC	P	Module Power Supply	

6	WPS	I	WPS pin	
7	NC			
8	NC			

PCB Dimensions

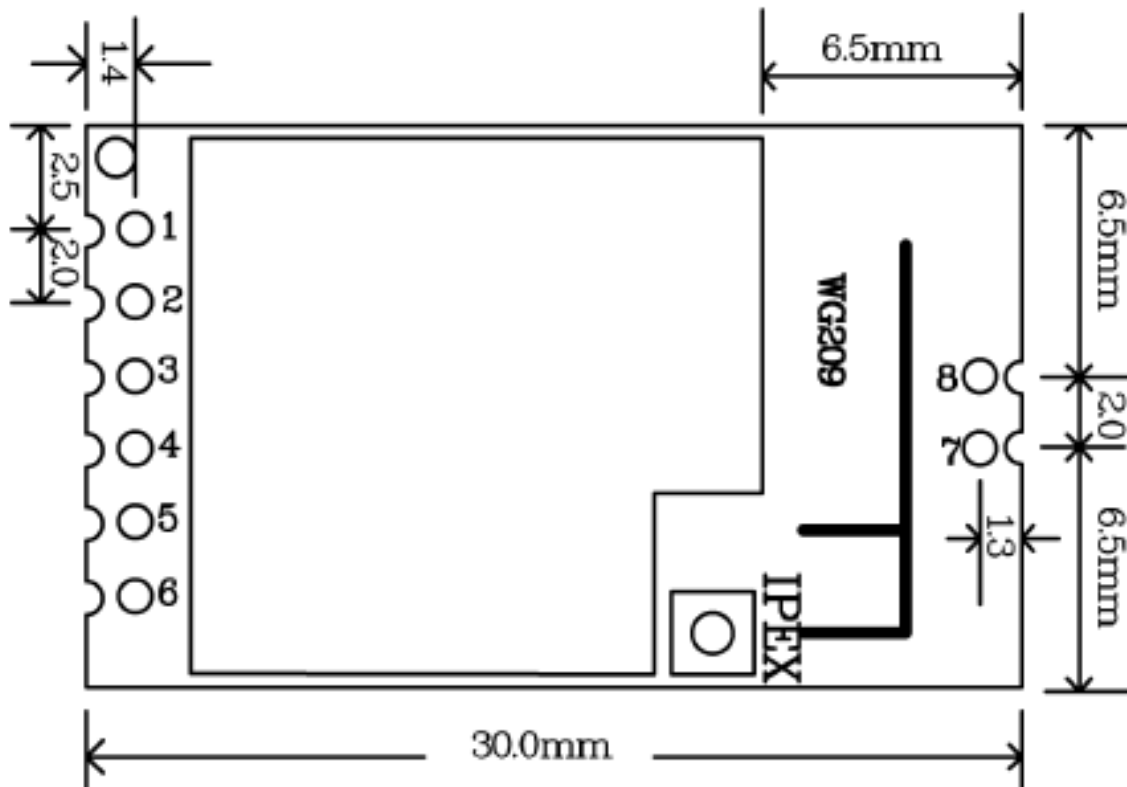

Figure 4: WG209 Dimensions

Reference design schematic

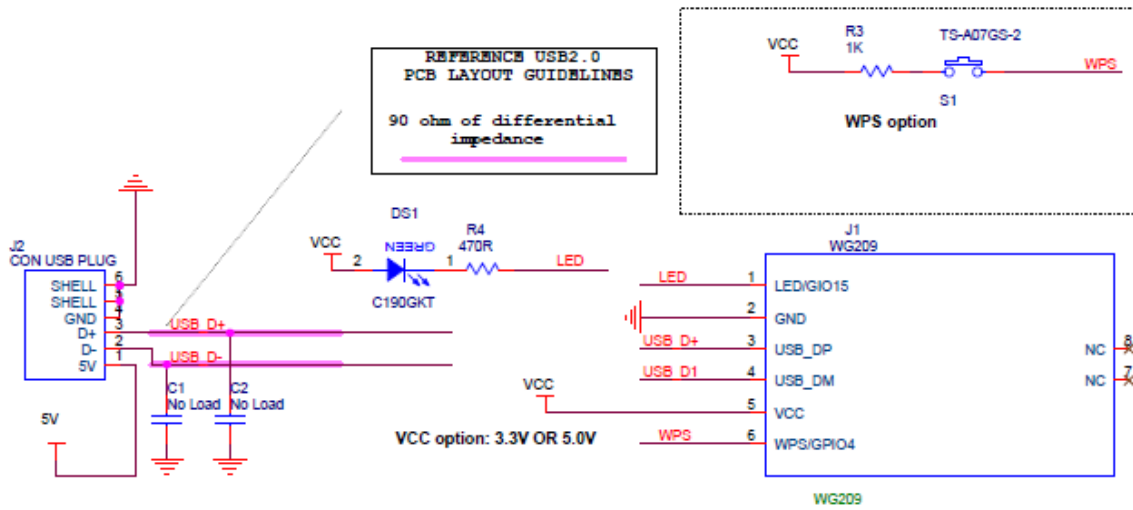

Figure 5: WG209 schematic application

Packaging Specification

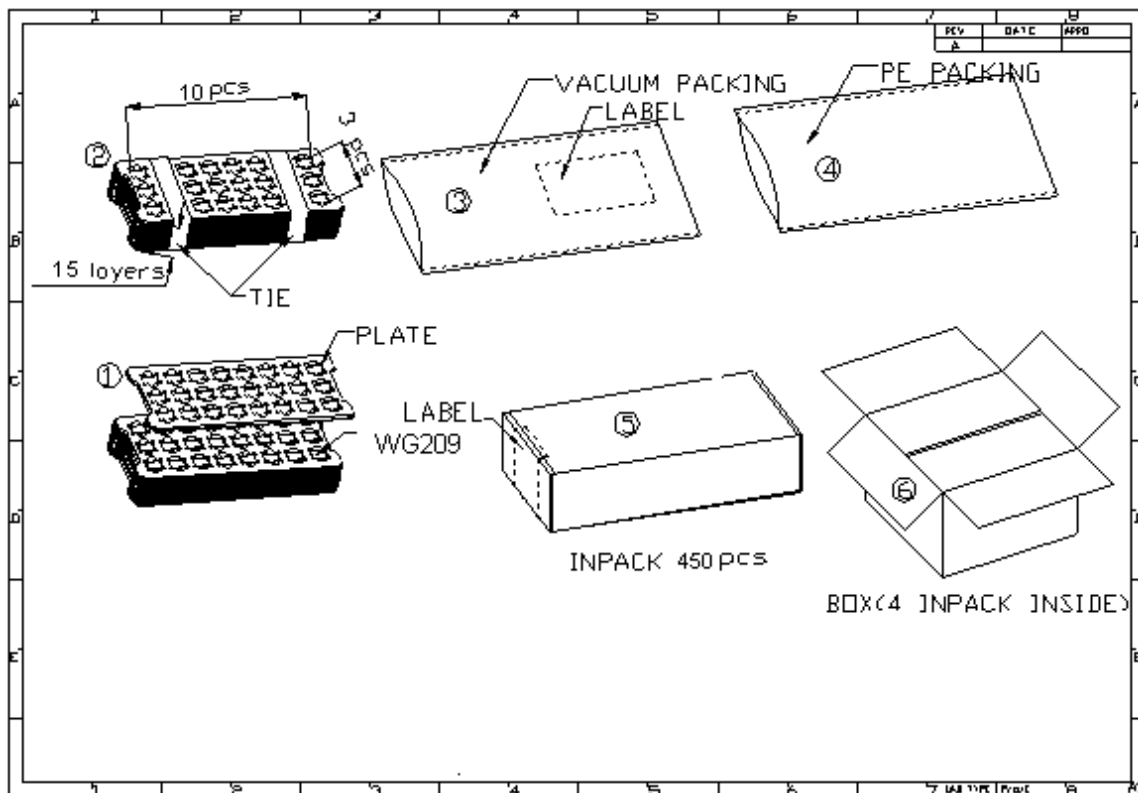

Figure 5: WG209 Packaging

Skylab M&C Technology Co., Ltd.

Address: 9th Floor, Zhongguang Building, Yayuan Road, Bantian, Shenzhen

Phone: **86-755 8340 8210** (Sales Support)

Phone: **86-755 8340 8130** (Technical Support)

Fax: **86-755-8340 8560**

E-Mail: sales1@skylab.com.cn

Website: www.skylab.com.cn